

Velleman Home Automation System



Velbus Timer Application

INTRODUCTION	3
The system in general	3
A few advantages of the velbus system.....	3
PURPOSE	4
NECESSARY EQUIPMENT	5
WIRING	6
SET-UP	7
Setting the relay module	7
<i>Terminator</i>	7
<i>Adressing</i>	7
<i>Mode & time setting</i>	7
Setting the control panel.....	8
<i>Terminator</i>	8
<i>Adressing</i>	8
Modifying the labels.....	9
<i>Set-up the labels</i>	9
Setting the push button reaction delays	11
Setting the clock	13
Setting the contrast and the backlight	14
LEARNING THE COMMANDS	16
Learning the push button which switches on the driveway lights	16
Learning the Push Button which switches off the driveway lights.....	17
Learning the push button which switches on the garden lights	18
Learning the push button which switches off the garden lights	19
Learning the push button which switches on the heating	20
Learning the push button which switches off the heating	21
Learning the push button which switches on the AC outlets	22
Learning the push button which switches off the AC outlets	23
USERMODE	24
PROGRAMMING THE TIMER	25
Entering the timer program	25
setting programming step 1	26
setting programming step 2	27
setting programming step 3	28
setting programming step 4	29
setting programming step 5	30
setting programming step 6	31
setting programming step 7	32
setting programming step 8 to 20	33
ACTIVATING THE TIMER PROGRAM	34
APPENDIX	36
Erasing all learned push buttons from channel 1 in the relay module	37
Erasing all learned push buttons from channel 2 in the relay module	38
Erasing all learned push buttons from channel 3 in the relay module	39
Erasing all learned push buttons from channel 4 in the relay module	40

INTRODUCTION

Finally! Here is no-nonsense home automation which is easy to install and to maintain, both for the qualified technician as for the DIY enthusiast. The system does not contain any (costly) central unit, which makes it extremely user-friendly, reliable and inexpensive.

The VELBUS can be set up and controlled using the classic learning method as well as with a few clicks of the mouse through your computer. The necessary software is available for free.

THE SYSTEM IN GENERAL:

The Velbus system is a 4 wire system, connecting all the modules. From the 4 wires 2 are power supply and 2 are data making it extremely reliable. Each module can be placed anywhere on the bus, making it really plug and play and easily expandable.

Controlling the output modules can be done using a small 8 channel interface module or using our advanced Push button and timer panel. There is always indication feedback of your action using LED's. From manual controlling to automation, the Velbus is what you need.

A FEW ADVANTAGES OF THE VELBUS SYSTEM:

- The DIY enthusiast can now enjoy home automation thanks to its easy installation and competitive price.
- Little critical wiring: star / loop / bus wiring, etc.
- Easy learning function, PC is optional.
- User friendly system configuration and modification.
- The system does not contain any (costly) central unit, which makes it extremely reliable.
- Simultaneous operation of several push buttons, unlike some competing systems.







PURPOSE

This example will show how to turn a control panel and a relay module into a timer.

A control panel and a 4-channel relay module can be used to:

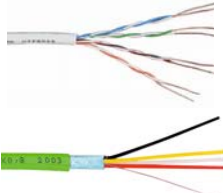
- switch the driveway light on or off
- switch on the driveway lights every day at 20h00
- switch off the driveway light every day at 23h00
- switch the garden lights on or off
- switch on the garden lights every day at 06h00
- switch off the garden lights from Monday to Friday at 10h00
- switch off the garden lights on Saturday and Sunday at 23h30
- switch the heating on or off
- switch on the heating every day at 06h00
- switch off the heating from Monday to Friday at 22h00
- switch off the heating on Saturday and Sunday at 23h30
- switch the AC outlets in the hobby room on or off
- switch on the AC outlets every day at 06h00
- switch off the AC outlets every day at 23h30
- set the control panel's backlight to full intensity at 07h00
- lower the control panel's backlight intensity at 21h00

NECESSARY EQUIPMENT

	<i>Description</i>	<i>Type</i>	<i>Quantity</i>
	<p style="text-align: center;"><u>Control Panel :</u></p> <p>This unique panel will let you control all of the output modules on the Velbus system, no need to remember the function of each button, just read the label next to it! The module also features programmable timing functions to automate button press actions at a certain time in the day, there are weekly or daily program steps possible. An infrared receiver is also incorporated.</p>	VMB4PD	1
	<p style="text-align: center;"><u>4-Channel Relay Module</u></p> <ul style="list-style-type: none"> • 4 independent relay outputs: • switching capacity with a resistive load: 16A/230VAC max • switching capacity with an inductive load: 8A/230VAC max. • power supply: 12VDC - 18VDC • consumption all relays activated: 330mA/18VDC • consumption in standby: 50mA/16VDC • 8 different operation possibilities • 10 different operation modes • 16 time settings: moment - 5s - 10s - 15s - 30s - 1min - 2 min - 5min - 10min - 15min - 30min - 1h - 2h - 5h - 1day - on/off • 9 different time settings for timer 2: 5min - 10min - 15min - 30min - 1h - 2h - 5h - 1day - on/off 	VMB4RY	1
	<p style="text-align: center;"><u>Power Module</u></p> <ul style="list-style-type: none"> • short-circuit safe • three 12VDC/1A outputs for powering VELBUS modules • connectable to transformer with 1 x 12V or 2 x 12V secondary voltages 	VMB3PS	1
	<p style="text-align: center;"><u>Velbus data cable :</u></p> <ul style="list-style-type: none"> • UTP cable category 5E • 4 pairs, coloured • PVC outside • meter mark • "S" type: multicore 	EIB 2x2x0.8mm2 UTP 8x0.51mm Or equal	-
	Circuit breaker	10A	1
	Circuit breaker	16A	1
	Double-pole auxiliary relay	16A	1
	Transformer	230V/12V~ (8VA)	1

WIRING

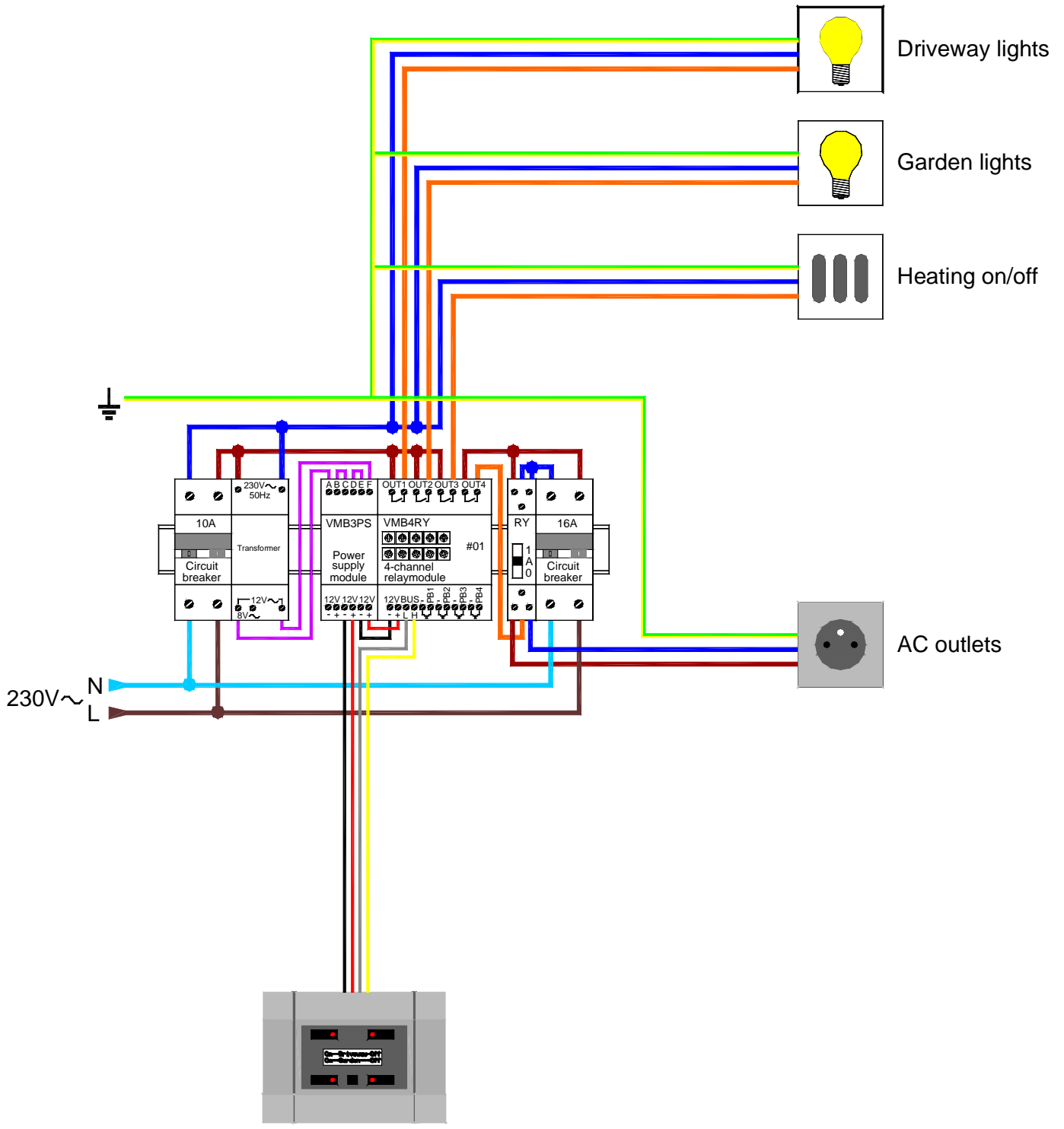

Remark: AC outlets must always have a double-pole interruption. Therefore, output 4 of the relay module will activate an extra double-pole relay.

A) Setting the relay module

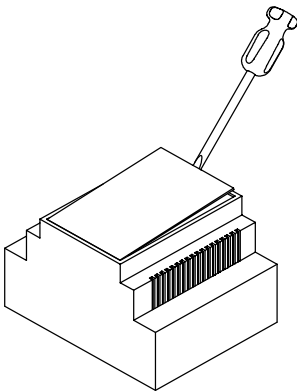

Remove the relay module cover using a small screwdriver in order to have access to the rotary switches.

Terminator:

Place a terminator at the beginning and the end of the bus. Place the TERM terminator at the beginning of the bus as the relay module will be connected at the beginning.



Addressing

Each module connected to the Velbus® system must have a unique address. Set the address of the relay module on "01" via the "ADDR" rotary switches.

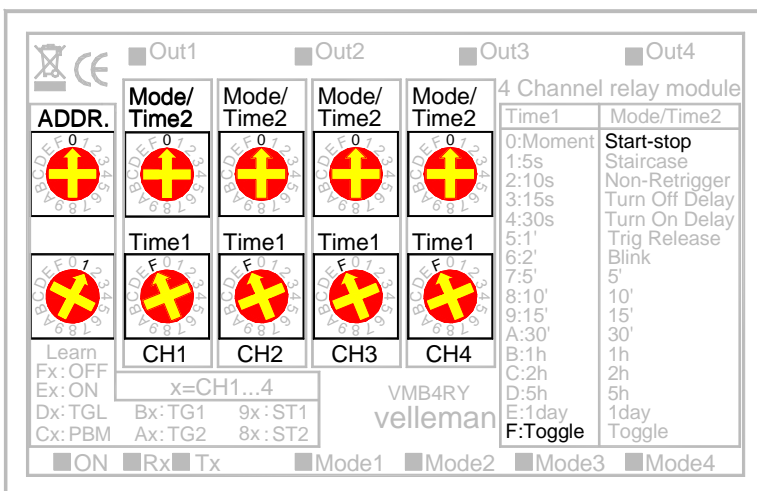

Mode and Time Settings

The 4 channels must act as on/off. Set the "MODE" rotary switches on "0".
No switch-off delays are used for the 4 channels. Set the "TIME" rotary switches on "F".

Replace the cover onto the module.

B) Setting the control panel

Terminator

Place the TERM terminator as the control panel will be connected as the last device on the bus.



Addressing

Each module connected to the Velbus® system must have a unique address.

Set the address of the control panel on "02" as follows:

1. Apply voltage to the Velbus system.
2. Hold the configuration button pressed for 4 seconds to enter the configuration menu.
3. Press the configuration button again to enter the next configuration menu.
4. Press the upper right button to enter the address menu
5. Select the left address digit using the upper left button (blinking digit).
Select the right address digit using the upper right button (blinking digit).
Hold the lower left button pressed and press the lower right button to modify the selected address digit. Proceed to set the address on "02".
6. Press the configuration button to quit the address menu..

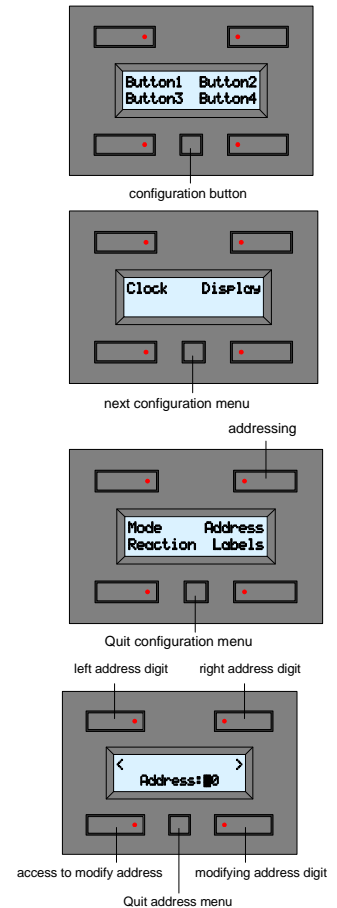

C) Modifying the labels

This control panel allows you to determine up to 8 commands. The module displays the first group of 4 commands by default (commands 1 to 4). Press the configuration button (small push button) to switch to the secondary group of commands (commands 5 to 8).

Example of command determination:

➤ Commands 1 to 4 (standard group of commands)

The upper left button will be used to switch on the driveway lights; the upper right button will be used to switch them off. The panel will display "On--Driveway--Off".
The lower left button will be used to switch on the garden lights; the lower right button will be used to switch them off. The panel will display "On---Garden---Off".

➤ Commands 5 to 8 (secondary group of commands)

The upper left button will be used to switch on the heating; the upper right button will be used to switch it off. The panel will display "On---Heating---Off".
The lower left button will be used to switch on the AC outlets; the lower right button will be used to switch them off. The panel will display "On--AC outlet--Off".

Set up the labels as follows:

1. Hold the configuration button pressed for 4 seconds to enter the configuration menu.

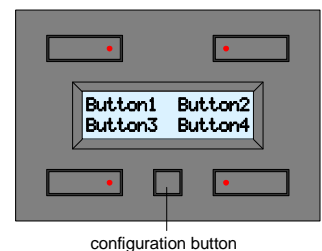

2. Press the configuration button again to enter the next configuration menu.

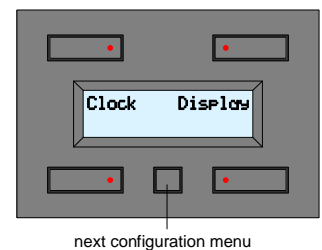

3. Press the lower right button to enter the label editor.

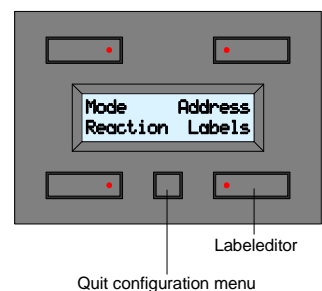

4. Move the cursor to the left or to the right using the upper buttons (see blinking character).
Select the character using the lower buttons.
Proceed to enter the text "On--Driveway--Off" and "On---Garden---Off".

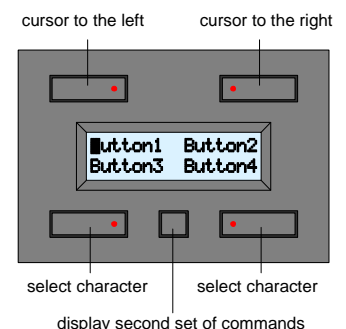

5. Press the configuration button to enter the secondary group of commands.

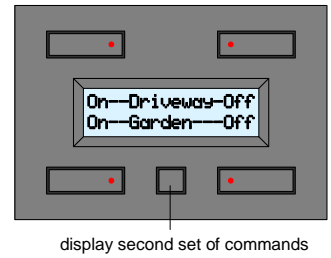

6. Move the cursor to the left or to the right using the upper buttons (see blinking character).
Select the character using the lower buttons.
Proceed to enter the text "On---Heating---Off" and "On-AC outlet-Off".

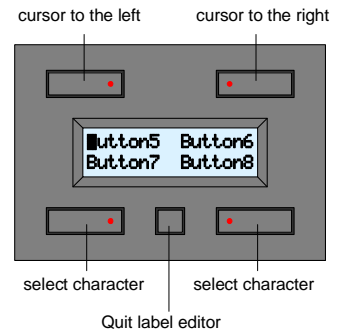

7. Press the configuration button to quit the label editor.

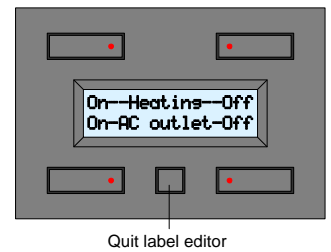

Remark : The labels can also be edited via "Velbuslink.exe" if the Velbus® system includes a USB or serial interface.

D) Setting the push button reaction delays

The commands have a short reaction delay by default. However, it is possible to set a reaction delay of 1, 2 or 3 seconds. In this example, all commands have a short reaction delay.

Modify the reaction delay as follows:

1. Hold the configuration button pressed for 4 seconds to enter the configuration menu.

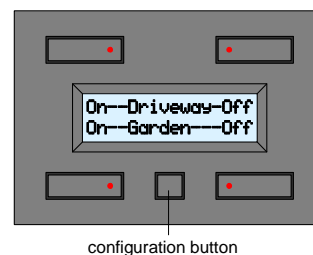

2. Press the configuration button again to enter the next configuration menu.

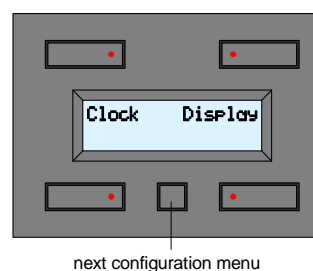

3. Press the lower left button to enter the reaction delay menu.

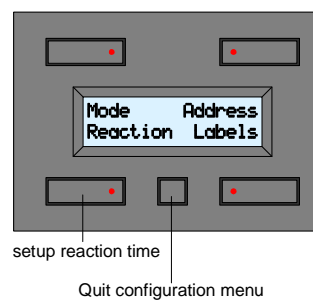

4. Press the lower buttons to set a reaction delay of 0s for the driveway lights command.

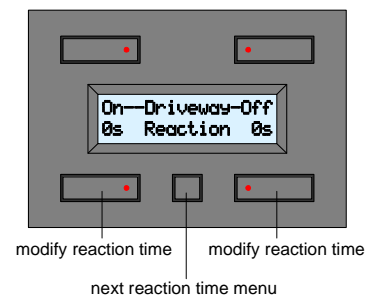

5. Press the lower buttons to set a reaction delay of 0s for the garden lights command.

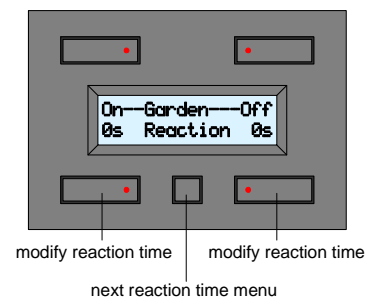

6. Press the lower buttons to set a reaction delay of 0s for the heating command.

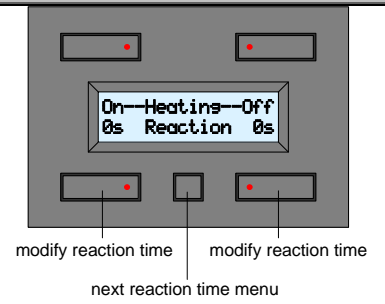

7. Press the lower buttons to set a reaction delay of 0s for the AC outlets command. Press the configuration button to quit the reaction delay menu.

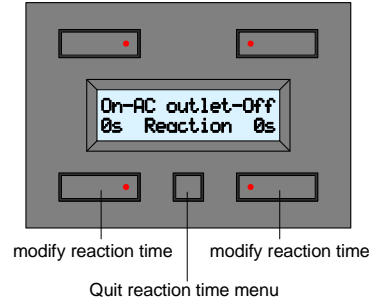

Remark : The reaction delays can also be set via "Velbuslink.exe" if the Velbus® system includes a USB or serial interface.

E) Setting the clock

1. Hold the configuration button pressed for 4 seconds to enter the configuration menu.

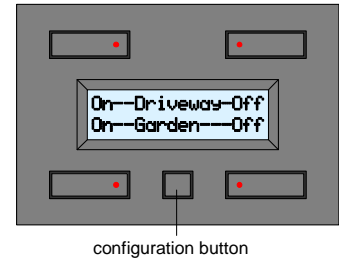

2. Press the upper left button to enter the clock menu.

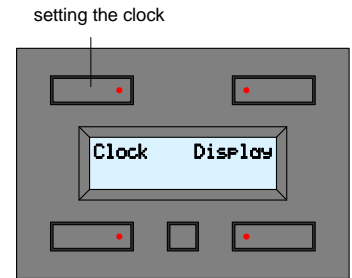

3. Press the upper right and lower buttons to set the time.

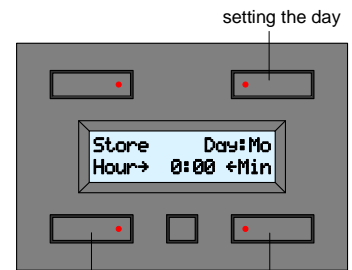

4. Wait until a minute has elapsed before confirming the time.

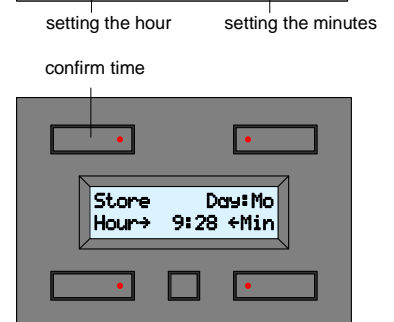

Remark: Connect a 9V battery via the included cable to power the internal clock in case of a power failure.

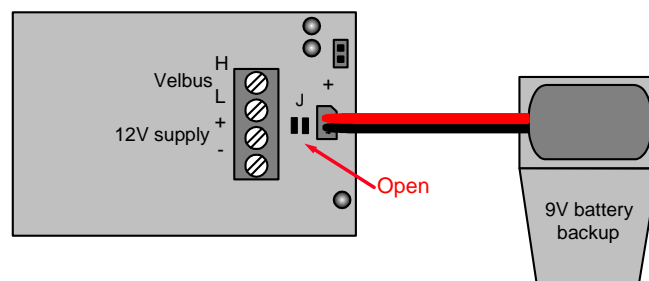

F) Setting the contrast and the backlight

The contrast and the backlight of the display, and the backlight of the buttons can be set according to your own needs. The backlight setting can be automated (example: the module will set the backlight to full intensity every day at 07h00 and lower it at 21h00).

1. Hold the configuration button pressed for 4 seconds to enter the configuration menu.

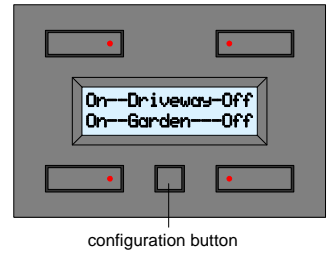

2. Press the upper right button to enter the display menu.

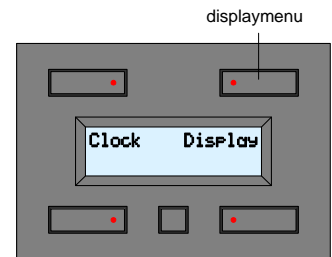

3. Press the upper buttons to modify the contrast. Press the lower left button to modify the display backlight. Press the lower right button to modify the button backlight.

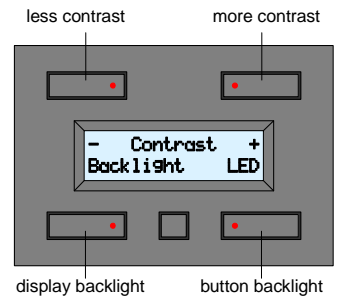

4. Press the configuration button to enter the next display menu.

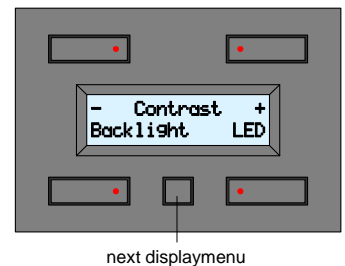

5. Press the upper right button to activate the backlight timer.

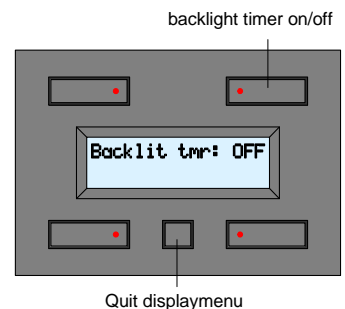

6. Press the configuration button to enter the backlight configuration menu.

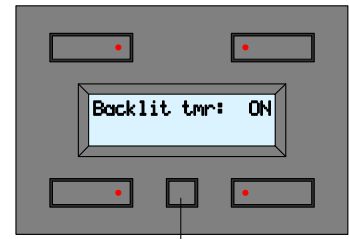

backlight configuration menu

7. Press the upper left button to set the time at 07h00. Press the upper right button to set the intensity to the maximum value (ON). Press the lower left button to set the time at 21h00. Press the lower right button to set the intensity to a lower value (LOW).

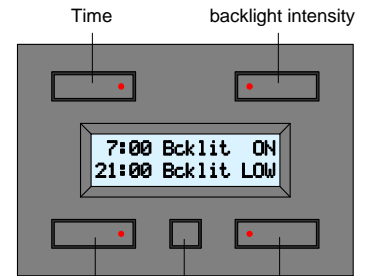

Time
backlight intensity
Time
backlight intensity
Quit displaymenu

LEARNING THE COMMANDS

To start with a virgin relay module, it is recommended to erase all previously learned push buttons first. See appendix on page 32.

A) Learning the push button which switches on the driveway lights

1. Remove the cover of the relay module.

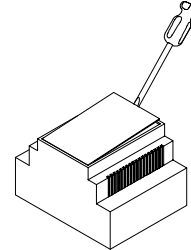

2. Set the relay module address on "E1" so as to learn the button which will switch on the driveway lights. The "Mode1" LED (CH1) will blink.

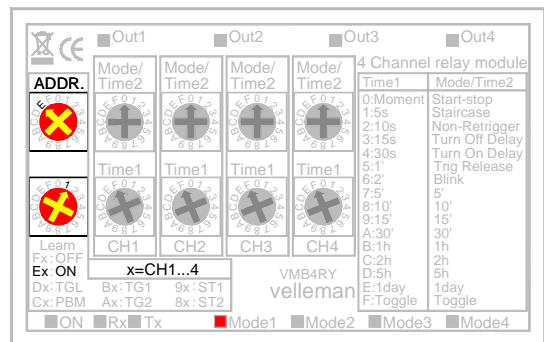

3. Hold the upper left button pressed until the driveway lights switch on (channel 1 on the relay module). Release the button to switch off the driveway lights.

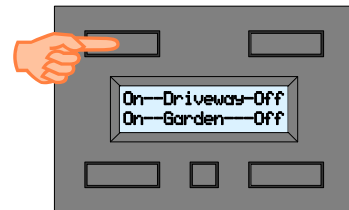

4. The upper left LED on the module will now blink indicating the button has been accepted.

Tip: Hold a learned push button (push button which indication LED blinks) pressed until the indication LED turns to erase the button

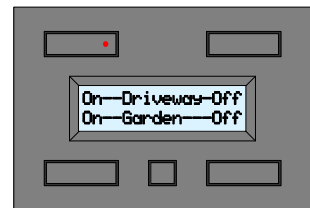

5. Reset the original value of the relay module on "01". The "Mode1" LED (CH1) on the relay module and the indication LED will turn off..

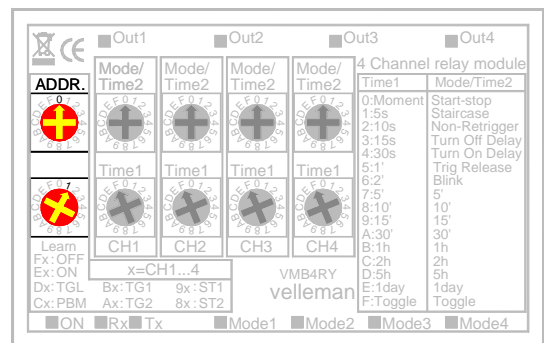

B) Learning the push button which switches off the driveway lights

1. Set the relay module address on "F1" so as to learn the button which will switch off the driveway lights. The "Mode1" LED (CH1) will blink.

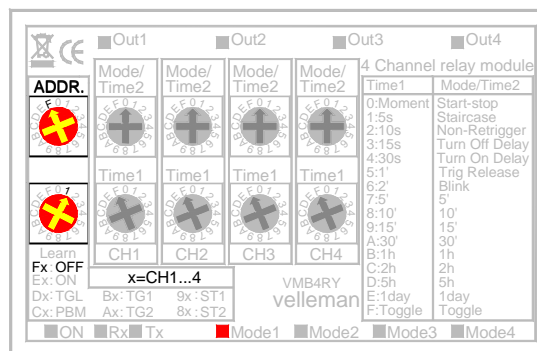

2. Hold the upper right button pressed until the driveway lights switch on (channel 1 on the relay module). Release the button to switch off the driveway lights.

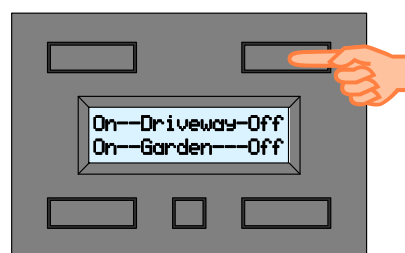

4. The upper right LED on the module will now blink indicating the button has been accepted.

Tip: Hold a learned push button (push button which indication LED blinks) pressed until the indication LED turns to erase the button.

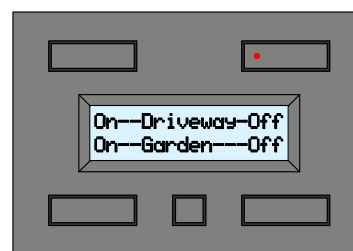

5. Reset the original value of the relay module on "01". The "Mode1" LED (CH1) on the relay module and the indication LED will turn off.

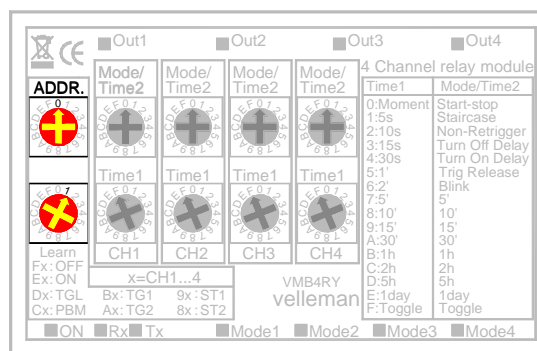

C) Learning the push button which switches on the garden lights

- Set the relay module address on "E2" so as to learn the button which will switch on the garden lights.
The "Mode2" LED (CH2) will blink.

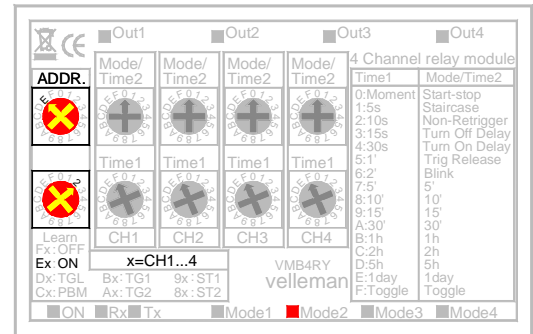

- Hold the lower left pressed until the garden lights switch on (channel 2 on the relay module).
Release the button to switch off the garden lights.

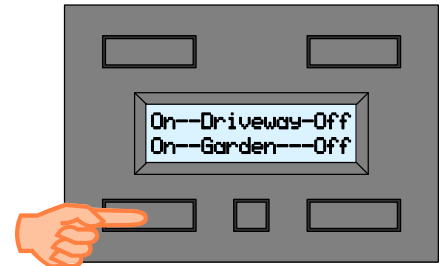

- The lower left LED on the module will now blink indicating the button has been accepted.

Tip: Hold a learned push button (push button which indication LED blinks) pressed until the indication LED turns to erase the button.

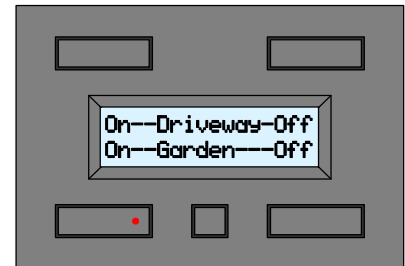

- Reset the original value of the relay module on "01".
The "Mode2" LED (CH2) on the relay module and the indication LED will turn off.

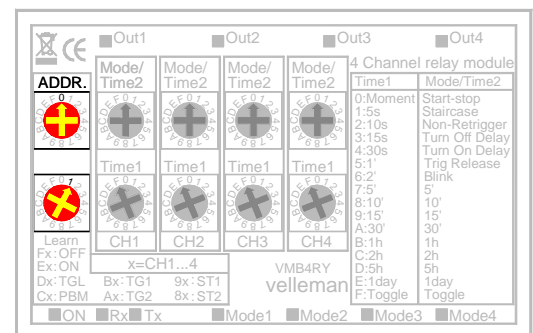

D) Learning the push button which switches off the garden lights

- Set the relay module address on "F2" so as to learn the button which will switch off the garden lights.
The "Mode2" LED (CH2) will blink.

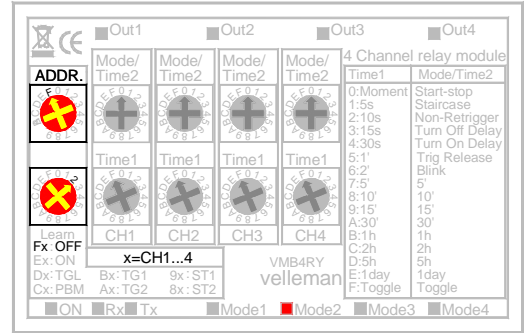

- Hold the lower right button pressed until the garden lights switch on (channel 2 on the relay module).
Release the button to switch off the garden lights.

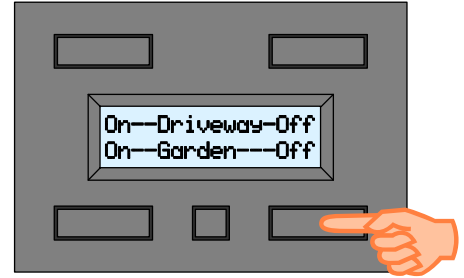

- The lower right LED on the module will now blink indicating the button has been accepted.

Tip: Hold a learned push button (push button which indication LED blinks) pressed until the indication LED turns to erase the button.

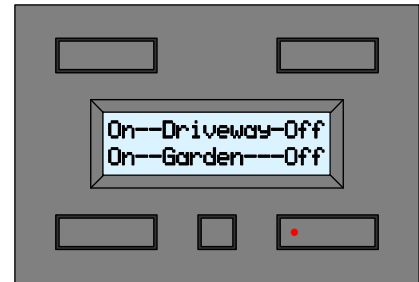

- Reset the original value of the relay module on "01".
The "Mode2" LED (CH2) on the relay module and the indication LED will turn off.

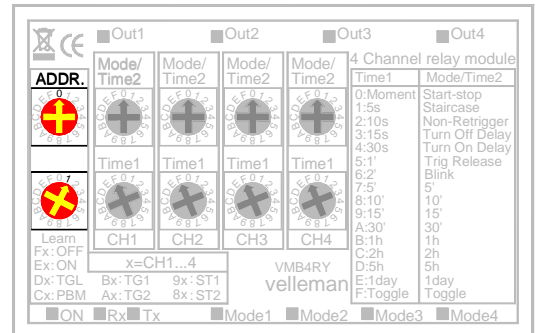

E) Learning the push button which switches on the heating

- Set the relay module address on "E3" so as to learn the button which will switch on the heating.
The "Mode3" LED (CH3) will blink..

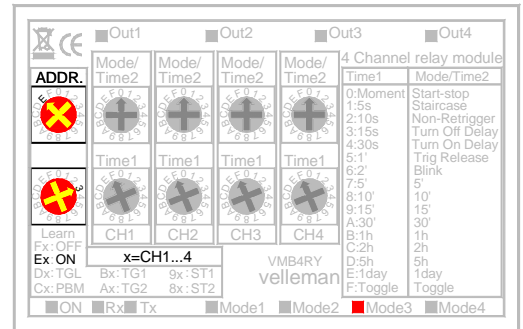

- Press the configuration button to enter the secondary group of commands.

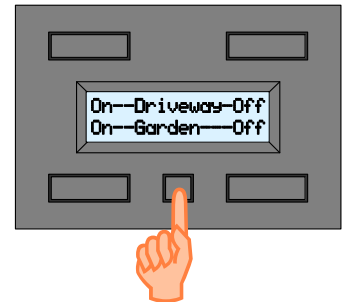

- Hold the upper left pressed until the heating switches on (channel 3 on the relay module).
Release the button to switch off the heating..

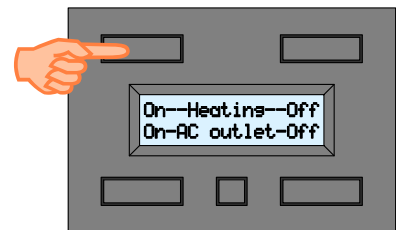

- The upper left LED on the module will now blink indicating the button has been accepted.

Tip: Hold a learned push button (push button which indication LED blinks) pressed until the indication LED turns to erase the button

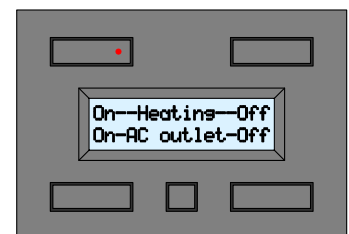

- Reset the original value of the relay module on "01".
The "Mode3" LED (CH3) on the relay module and the indication LED will turn off.

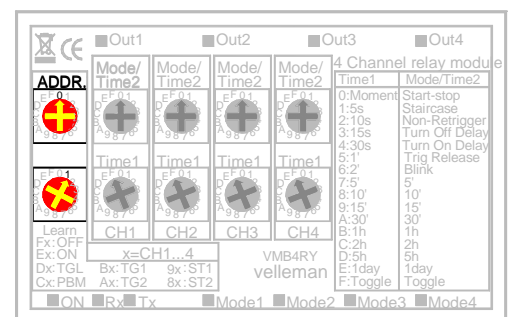

F) Learning the push button which switches off the heating

- Set the relay module address on "F3" so as to learn the button which will switch off the heating.
The "Mode3" LED (CH3) will blink.

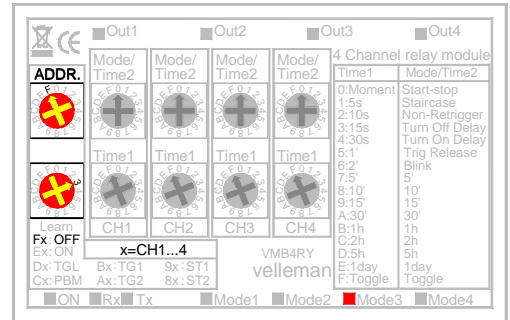

- Press the configuration button to enter the secondary group of commands.

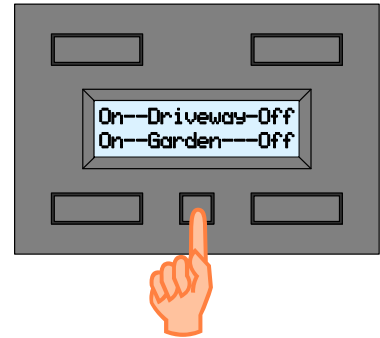

- Hold the upper right pressed until the heating switches on (channel 3 on the relay module).
Release the button to switch off the heating.

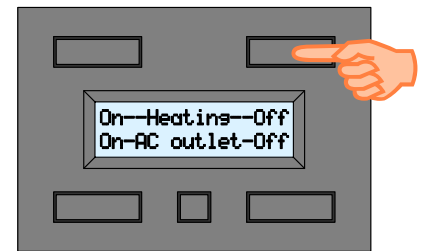

- The upper right LED on the module will now blink indicating the button has been accepted

Tip: Hold a learned push button (push button which indication LED blinks) pressed until the indication LED turns to erase the button.

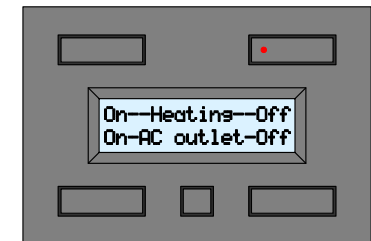

- Reset the original value of the relay module on "01".
The "Mode3" LED (CH3) on the relay module and the indication LED will turn off.

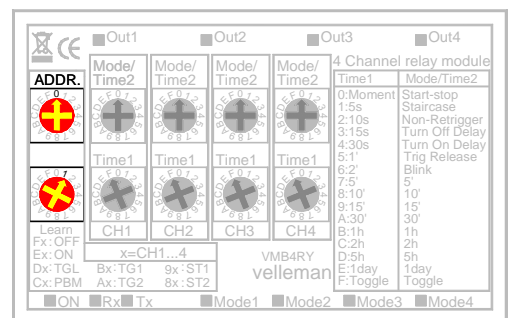

G) Learning the push button which switches on the AC outlets

- Set the relay module address on "E4" so as to learn the button which will switch on the AC outlets.
The "Mode4" LED (CH4) will blink.

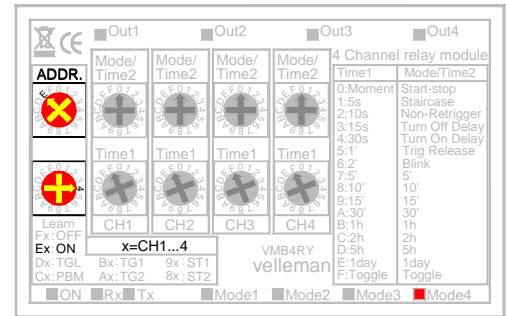

- Press the configuration button to enter the secondary group of commands.

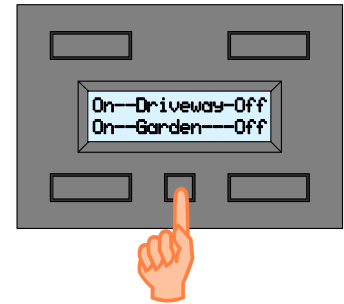

- Hold the lower left pressed until the AC outlets switch on (channel 4 on the relay module).
Release the button to switch off the AC outlets.

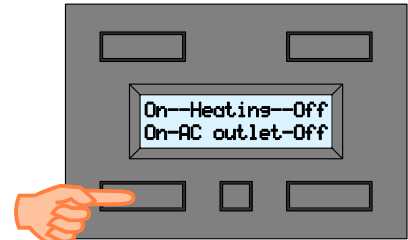

- The lower left LED on the module will now blink indicating the button has been accepted.

Tip: Hold a learned push button (push button which indication LED blinks) pressed until the indication LED turns to erase the button.

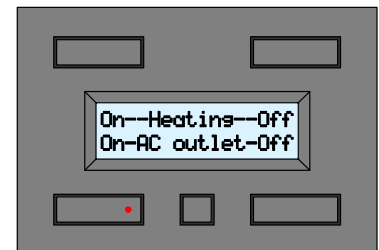

- Reset the original value of the relay module on "01".
The "Mode4" LED (CH4) on the relay module and the indication LED will turn off.

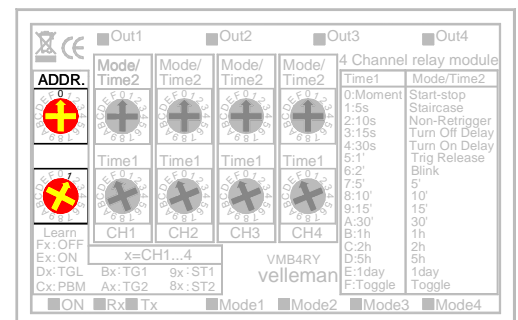

H) Learning the push Button which switches off the AC outlets

- Set the relay module address on "E4" so as to learn the button which will switch off the AC outlets.
The "Mode4" LED (CH4) will blink.

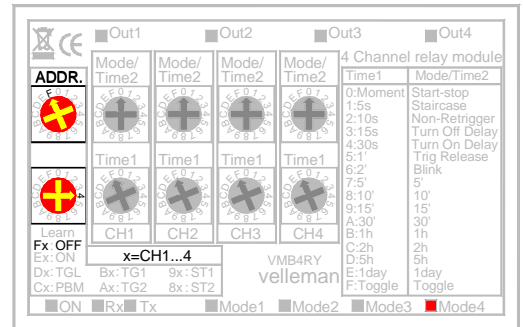

- Press the configuration button to enter the secondary group of commands.

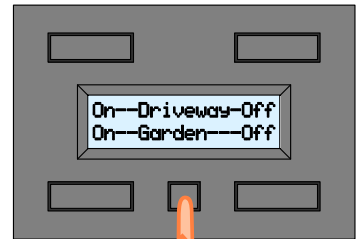

- Hold the lower right pressed until the AC outlets switch on (channel 4 on the relay module).
Release the button to switch off the AC outlets.

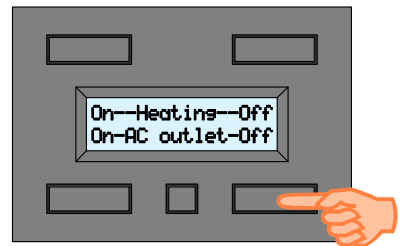

- The lower right LED on the module will now blink indicating the button has been accepted.

Tip: Hold a learned push button (push button which indication LED blinks) pressed until the indication LED turns to erase the button.



- Reset the original value of the relay module on "01".
The "Mode4" LED (CH4) on the relay module and the indication LED will turn off.
Close the relay module.

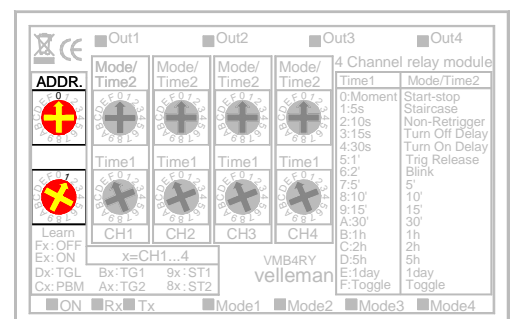

USERMODE

The timer is deactivated by default. In this example we would like to set a timer for all commands. This can be done by modifying the user mode so as to set a timer for all commands.

1. Hold the configuration button pressed for 4 seconds to enter the configuration menu.

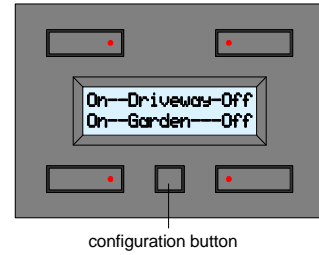

2. Press the configuration button again to enter the next configuration menu.

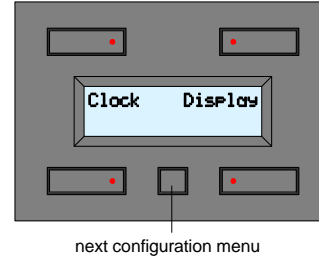

3. Press the upper left button to enter the mode menu.

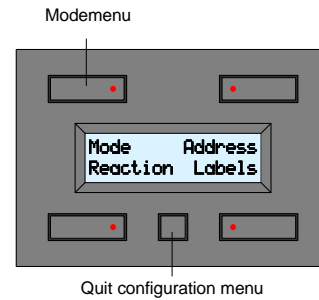

4. Press the upper right button to allow a timer function on all commands
(Timer mode: 8CH)

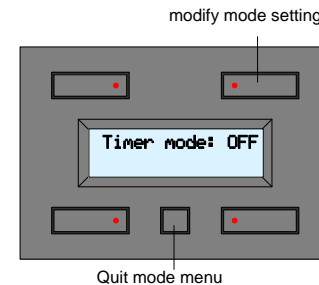

5. Press the configuration button to quit the mode menu.

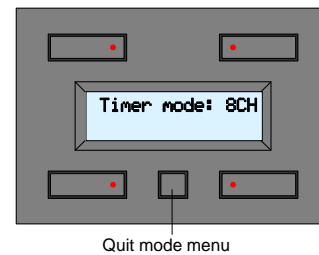

PROGRAMMING THE TIMER

Desired Timer Program:

- daily switch-on of the driveway lights at 08h00
- daily switch-off of the driveway lights at 23h00
- daily switch-on of the garden lights at 18h00
- switch-off of the garden lights at 22h00 on Monday through Friday
- switch-off of the garden lights at 23h30 on Saturday and Sunday
- daily switch-on of the heating at 06h00
- switch-off of the heating at 22h00 on Monday through Friday
- switch-off of the heating at 23h30 on Saturday and Sunday
- daily switch-on of the AC outlets at 06h00
- daily switch-off of the AC outlets at 23h30

Sketch of the Timer Program

Step n°	Day	Time	Action
1	Monday through Sunday	06h00	Heating On & AC outlets On
2	Monday through Sunday	18h00	Garden On
3	Monday through Sunday	20h00	Driveway On
4	Monday through Friday	22h00	Garden Off & Heating Off
5	Monday through Sunday	23h00	Driveway Off
6	Monday through Sunday	23h30	AC outlets Off
7	Saturday and Sunday	23h30	Garden Off & Heating Off

Entering the Timer program

- 1 Hold the configuration button pressed for 4 seconds to enter the configuration menu.

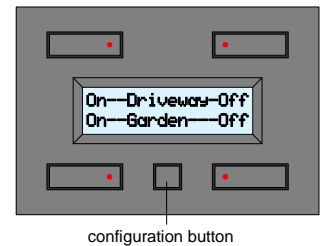

- 2 Press the lower left button to enter the program menu.

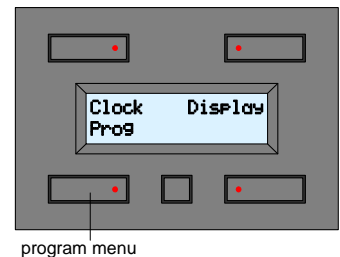

- 3 The first programming step is displayed.

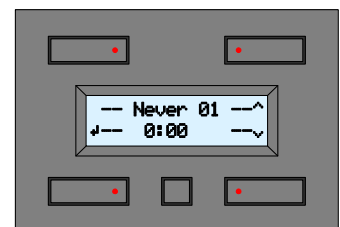
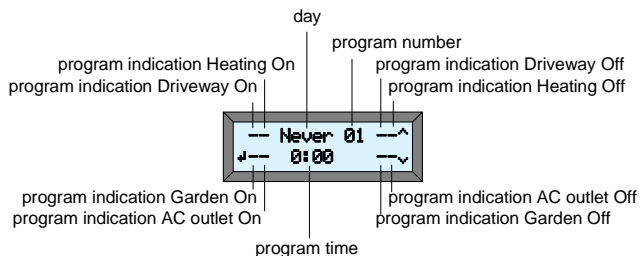

The program indication indicates whether the command has been accepted or not.

- : not accepted

⊕ : accepted. The command will be automatically executed at the set time.

Setting programming step 1

Monday through Sunday 06h00 Heating On & AC outlets On

4. Press the lower left button to modify the first programming step.

5. Press the upper right button to set the day range from Monday through Sunday (Mo-Su).
Press the lower buttons to set the time.
Press the configuration button to enter the next display.

6. The driveway lights commands must not be memorized into the programming step.
Press the lower buttons until a dash appears on the display.
Press the configuration button to enter the next display.

7. The garden lights commands must not be memorized into the programming step.
Press the lower buttons until a dash appears on the display.
Press the configuration button to enter the next display.

8. The command to switch on the heating must be memorized into the programming step.
Press the lower left button until a clock symbol appears on the display. Press the lower right button until a dash appears on the display.
Press the configuration button to enter the next display..

9. The command to switch on the AC outlets must be memorized into the programming step.
Press the lower left button until a clock symbol appears on the display. Press the lower right button until a dash appears on the display.
Press the configuration button to enter the next display.

10. Let's return to the sketch of the first programming step.
We can see that the heating and the AC outlets will be switched on daily at 06h00.

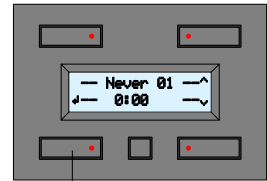

modify program step

setting the day



setting the hour

setting the minutes

next program step setting



add or remove

add or remove

next program step setting

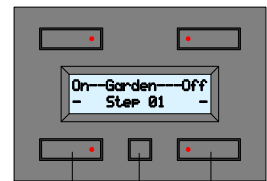

add or remove

add or remove

next program step setting



add or remove

add or remove

next program step setting



add or remove

add or remove

next program step setting

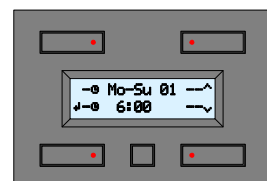

Setting programming step 2

Monday through Sunday

18h00

Garden On

11. Press the upper right button to enter the second programming step. Press the lower left button to modify the second programming step.

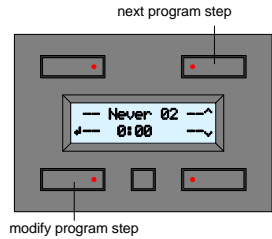

12. Press the upper right button to set the day range from Monday through Sunday (Mo-Su). Press the lower buttons to set the time at 18h00. Press the configuration button to enter the next display.

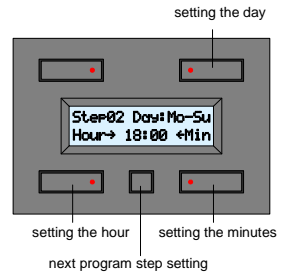

13. The driveway lights commands must not be memorized into the programming step. Press the lower buttons until a dash appears on the display. Press the configuration button to enter the next display.

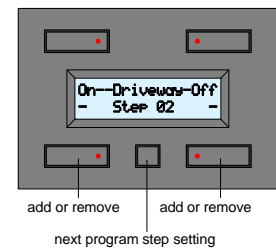

14. The command to switch on the garden lights must be memorized into the programming step. Press the lower left button until a clock symbol appears on the display. Press the lower right button until a dash appears on the display. Press the configuration button to enter the next display.

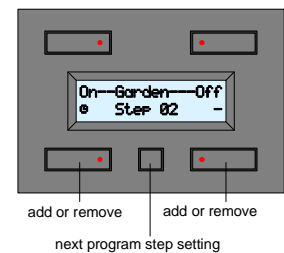

15. The heating commands must not be memorized into the programming step. Press the lower buttons until a dash appears on the display. Press the configuration button to enter the next display.

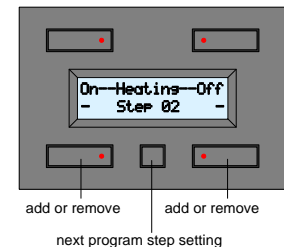

16. The AC outlet commands must not be memorized into the programming step. Press the lower buttons until a dash appears on the display. Press the configuration button to enter the next display.

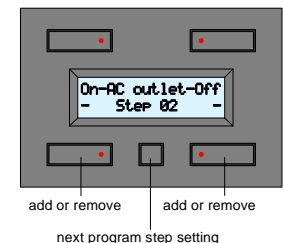

17. Let's return to the sketch of the second programming step. We can see that the garden lights will be switched on daily at 18h00.

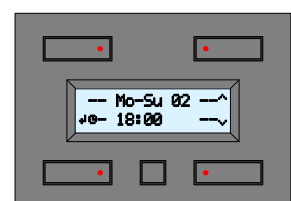

Setting programming step 3

Monday through Sunday

20u00

Driveway On

18. Press the upper right button to enter the third programming step. Press the lower left button to modify the third programming step.
19. Press the upper right button to set the day range from Monday through Sunday (Mo-Su). Press the lower buttons to set the time at 20h00. Press the configuration button to enter the next display.
20. The command to switch on the driveway lights must be memorized into the programming step. Press the lower left button until a clock symbol appears on the display. Press the lower right button until a dash appears on the display. Press the configuration button to enter the next display.
21. The garden lights commands must not be memorized into the programming step. Press the lower buttons until a dash appears on the display. Press the configuration button to enter the next display.
22. The heating commands must not be memorized into the programming step. Press the lower buttons until a dash appears on the display. Press the configuration button to enter the next display.
23. The AC outlets commands must not be memorized into the programming step. Press the lower buttons until a dash appears on the display. Press the configuration button to enter the next display.
24. Let's return to the sketch of the third programming step. We can see that the driveway lights will be switched on daily at 20h00.

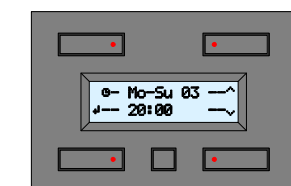
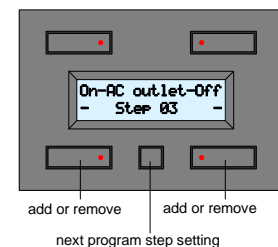
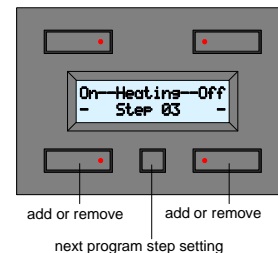
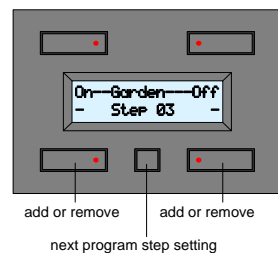
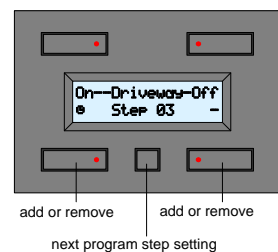
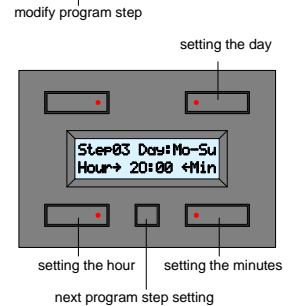
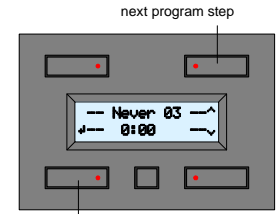

Setting programming step 4

Monday through Friday 22u00 Garden Off & Heating Off

25. Press the upper right button to enter the fourth programming step. Press the lower left button to modify the fourth programming step.

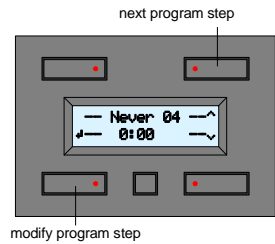

26. Press the upper right button to set the day range from Monday through Friday (Mo-Fr). Press the lower buttons to set the time at 22h00. Press the configuration button to enter the next display.

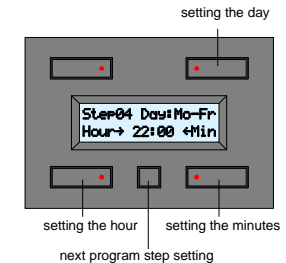

27. The driveway lights commands must not be memorized into the programming step. Press the lower buttons until a dash appears on the display. Press the configuration button to enter the next display.

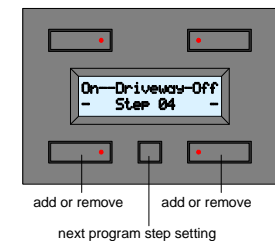

28. The command to switch off the garden lights must be memorized into the programming step. Press the lower left button until a dash appears on the display. Press the lower right button until a clock symbol appears on the display. Press the configuration button to enter the next display.

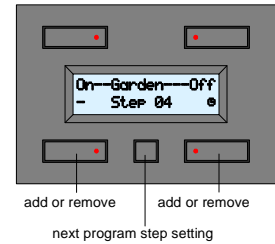

29. The command to switch off the heating must be memorized into the programming step. Press the lower left button until a dash appears on the display. Press the lower right button until a clock symbol appears on the display. Press the configuration button to enter the next display.

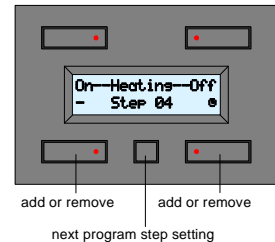

30. The AC outlets commands must not be memorized into the programming step. Press the lower buttons until a dash appears on the display. Press the configuration button to enter the next display.

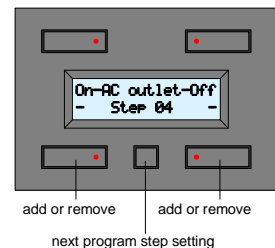

31. Let's return to the sketch of the fourth programming step. We can see that the heating and the garden lights will be switched off Monday through Friday at 22h00.

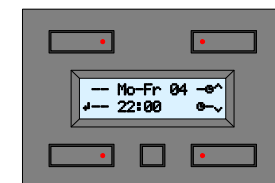

Setting programming step 5

Monday through Sunday

23u00

Driveway Off

32. Press the upper right button to enter the fifth programming step. Press the lower left button to modify the fifth programming step..

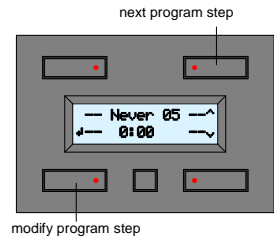

33. Press the upper right button to set the day range from Monday through Sunday (Mo-Su). Press the lower buttons to set the time at 23h00. Press the configuration button to enter the next display.

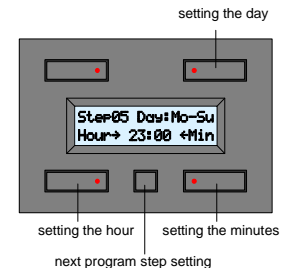

34. The command to switch off the driveway lights must be memorized into the programming step. Press the lower left button until a dash appears on the display. Press the lower right button until a clock symbol appears on the display. Press the configuration button to enter the next display.

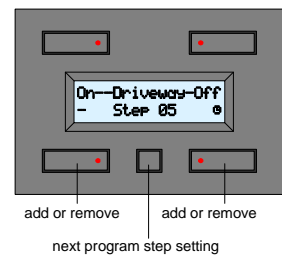

35. De bedieningen voor de tuinverlichting moeten niet opgenomen worden in deze programmastep. Bedien daarom de drukknop links- en rechtsonder tot een streepje op het scherm verschijnt. Bedien daarna de configuratiedrukknop om naar het volgende scherm over te gaan.

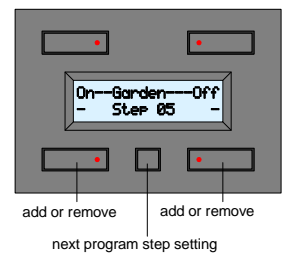

36. The garden lights commands must not be memorized into the programming step. Press the lower buttons until a dash appears on the display. Press the configuration button to enter the next display.

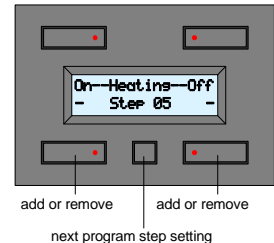

37. The AC outlets commands must not be memorized into the programming step. Press the lower buttons until a dash appears on the display. Press the configuration button to enter the next display.

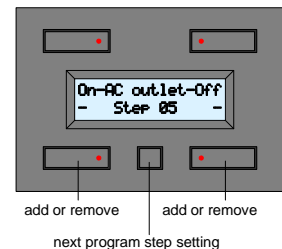

38. Let's return to the sketch of the fifth programming step. We can see that the garden lights will be switched off daily at 23h00.

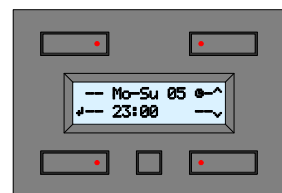

Setting programming step 6

Monday through Sunday

23u30

AC outlets Off

39. Press the upper right button to enter the sixth programming step. Press the lower left button to modify the sixth programming step.
40. Press the upper right button to set the day range from Monday through Sunday (Mo-Su). Press the lower buttons to set the time at 23h30. Press the configuration button to enter the next display.
41. The driveway lights commands must not be memorized into the programming step. Press the lower buttons until a dash appears on the display. Press the configuration button to enter the next display..
42. The garden lights commands must not be memorized into the programming step. Press the lower buttons until a dash appears on the display. Press the configuration button to enter the next display.
43. The heating commands must not be memorized into the programming step. Press the lower buttons until a dash appears on the display. Press the configuration button to enter the next display.
44. The command to switch off the AC outlets must be memorized into the programming step. Press the lower left button until a dash appears on the display. Press the lower right button until a clock symbol appears on the display. Press the configuration button to enter the next display.
45. Let's return to the sketch of the sixth programming step. We can see that the AC outlets will be switched off daily at 23h30.

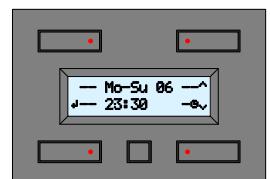
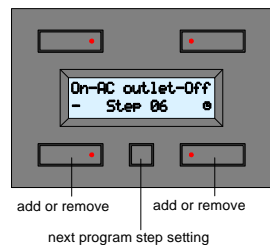
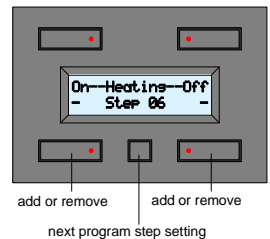
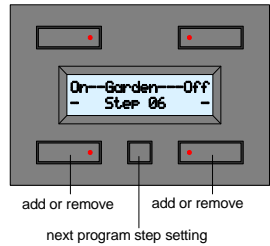
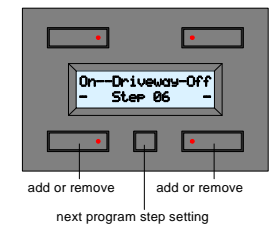
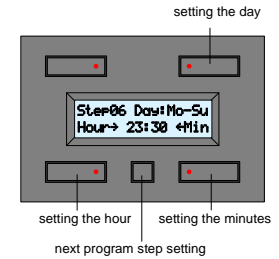
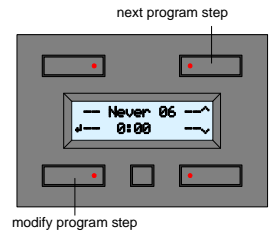

Setting programming step 7

Saturday and Sunday

23u30

Garden Off & Heating Off

46. Press the upper right button to enter the seventh programming step. Press the lower left button to modify the seventh programming step.
47. Press the upper right button to set the day range at Saturday and Sunday (*Sa-Su*). Press the lower buttons to set the time at 23h30. Press the configuration button to enter the next display.
48. The driveway lights commands must not be memorized into the programming step. Press the lower buttons until a dash appears on the display. Press the configuration button to enter the next display.
49. The command to switch off the garden lights must be memorized into the programming step. Press the lower left button until a dash appears on the display. Press the lower right button until a clock symbol appears on the display. Press the configuration button to enter the next display.
50. The command to switch off the heating must be memorized into the programming step. Press the lower left button until a dash appears on the display. Press the lower right button until a clock symbol appears on the display. Press the configuration button to enter the next display.
51. The AC outlets commands must not be memorized into the programming step. Press the lower buttons until a dash appears on the display. Press the configuration button to enter the next display.
52. Let's return to the sketch of the seventh programming step. We can see that the garden lights and the AC outlets will be switched off Saturday and Sunday at 23h30.

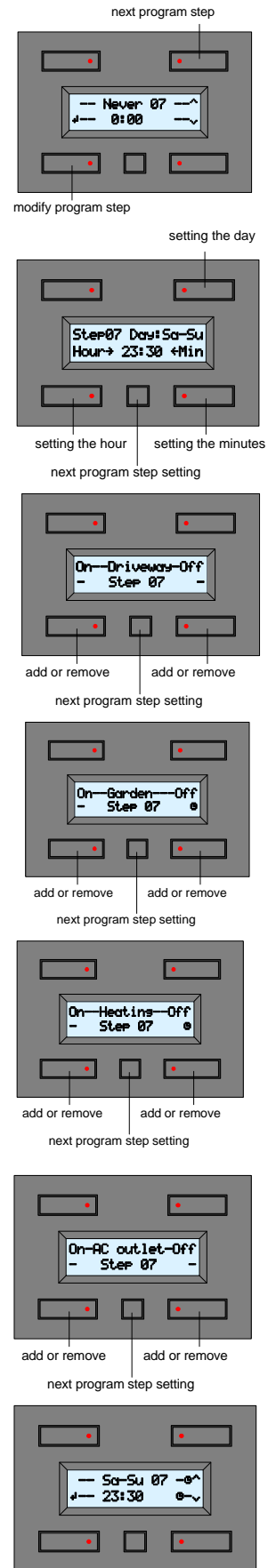

Checking programming steps 8 to 20

53. Press the upper right button to enter the eighth programming step.
Check if the day range is set on "Never" meaning the step will never be executed. Press the lower left button to modify if necessary.

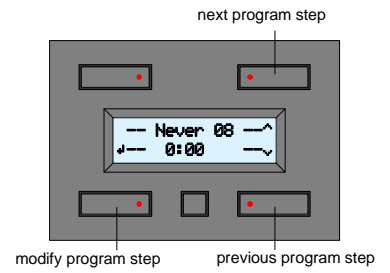

54.
...
64. Proceed as described above to control all remaining programming steps.

65. Press the upper right button to enter the final programming step.
Check if the day range is set on "Never" meaning the step will never be executed. Press the lower left button to modify if necessary.
Press the configuration button to quit the program menu.

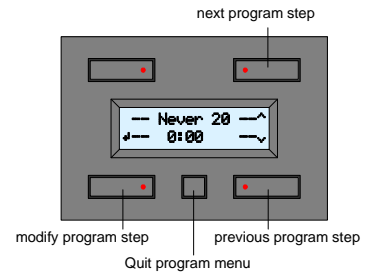

ACTIVATING THE TIMER PROGRAM

The entered program will only be executed if the timer function for the commands is activated. Place the display in time mode and check the indicators to make sure whether the program will be executed or not.

1. Press the configuration button to enter the secondary group of commands..

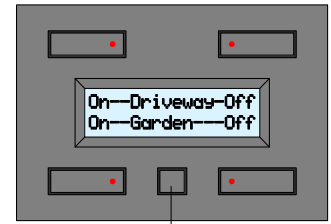

configuration button

2. Press the configuration button again to display the time.

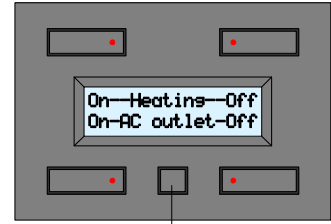

configuration button

3. The actual time and a summary of the activated timer programs will be displayed

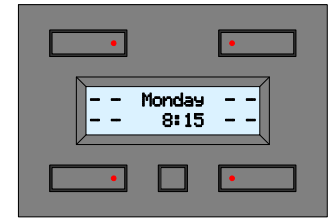
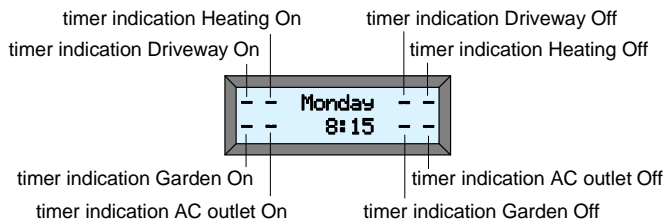

The timer indication means:

- “ ”: the command will not be used in the timer program.
- “-”: the timer program for a particular command will not be executed.
- “☑” : the timer program for a particular command is activated.

Tip: To disable the timer program, e.g. during holidays, it is not necessary to modify the timer program. Deactivate the timer function for the corresponding command instead.

How to activate or deactivate the timer program for the commands:

1. Hold the configuration button pressed for 4 seconds to enter the configuration menu.
2. Press the lower right to enter the timer activation menu.
3. Press the lower buttons until an hourglass appears on the display. The driveway lights switch-on/off timer program will now be executed.
4. Press the lower buttons until an hourglass appears on the display. The garden lights switch-on/off timer program will now be executed.
5. Press the lower buttons until an hourglass appears on the display. The heating switch-on/off timer program will now be executed.
6. Press the lower buttons until an hourglass appears on the display. The AC outlets switch-on/off timer program will now be executed.
7. An overview of all active timer programs for the commands will now be displayed. Press the configuration button to display the command labels or the actual time.

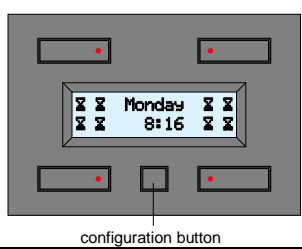
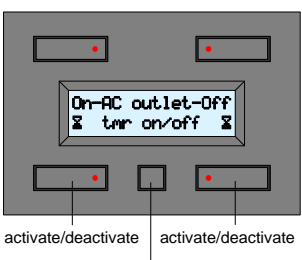
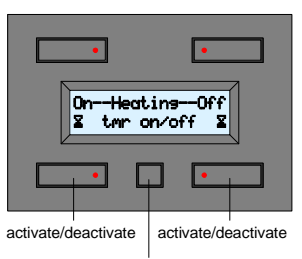
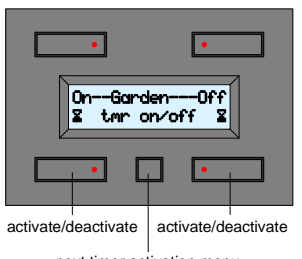
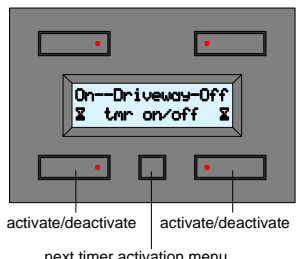
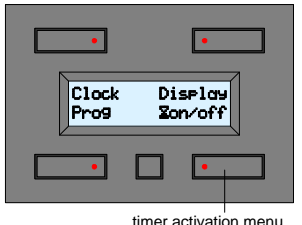
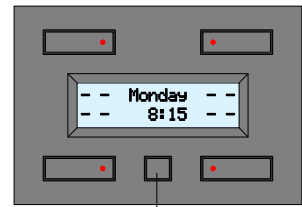

Network

But



Living Room Lighting

Chandelier

Mood lighting

Unused

Unused

Bedroom

Left blind

Right blind

Main Hall

Floor

Porcl

Unus

Unus

Unus

Wall

Garage

Gara

Right blind

Timeout: 15s

Roll Up

Roll Down

Halt

day

hour

min

sec

0

0

0

0

Use custom timeout

Traffic log

Addr.	Time
FC	27/03/2007 15:10:2
FD	27/03/2007 15:10:2
FE	27/03/2007 15:10:2
FF	27/03/2007 15:10:2
02	27/03/2007 15:10:45
02	27/03/2007 15:10:45
02	27/03/2007 15:10:45
02	27/03/2007 15:10:45
04	27/03/2007 15:12:26
04	27/03/2007 15:12:26
04	27/03/2007 15:12:26
04	27/03/2007 15:12:26



Status

Release

Off

Package

Package

Ad

vanced

00 00

00 07

1 00 00

Erasing all learned push buttons from channel 1 in the relay module

1. Remove the cover of the relay module

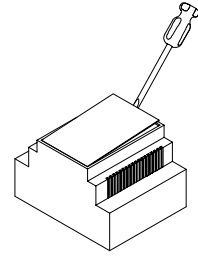

2. Set the relay module address on F1 to erase the push buttons with switch-off function.
The "Mode1" LED (CH1) will blink.

Tip: To erase another push button group, select the learning address of that group. Example: "E1" to erase all push buttons with switch-on function or "D1" to erase all push buttons with switch-on/off function

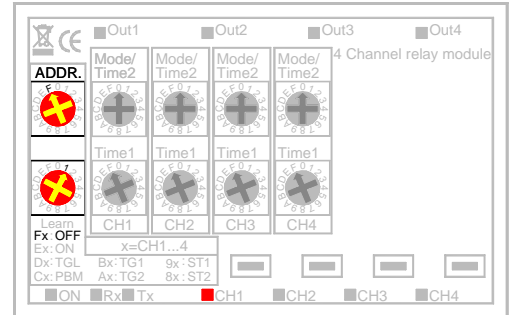

3. Hold the manual command for channel 1 pressed until the relay is activated (see LED OUT1).
Release the push button to erase all learned push buttons of the selected function from the module.

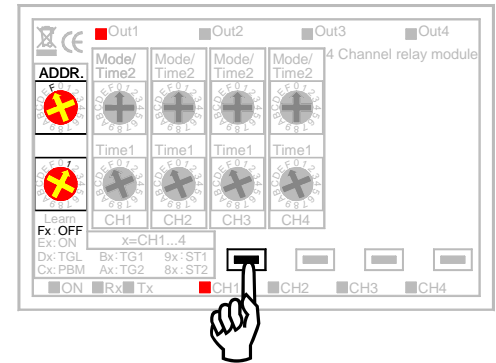

Some versions of the relay module allow you to erase all learned push buttons in one action. To do so, hold the manual push button pressed for 10 seconds. The relay will activate and then deactivate after 7 seconds. The deactivation indicates that all learned push buttons for channel 1 have been erased.

Erase all push buttons groups separately if the relay has not deactivated.

Set the address on "E1" and press the manual command until the relay activates. The push buttons with switch-on function for channel 1 are now erased.

Repeat this for addresses "D1", "C1", "B1", "A1", "91" and "81".

4. Reset the original address of the relay module on "01".
The "Mode1" LED (CH1) on the relay module and the indication LED will turn off.

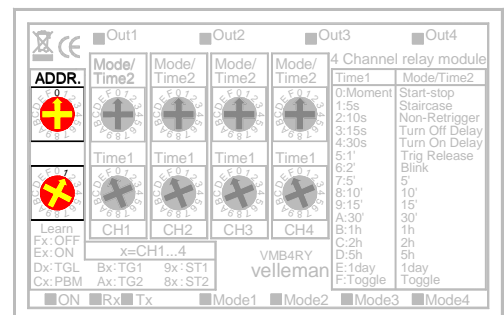

Erasing all learned push buttons from channel 2 in the relay module

- Set the relay module address on F2 to erase the push buttons with switch-off function. The "Mode2" LED (CH2) will blink.

Tip: To erase another push button group, select the learning address of that group. Example: "E2" to erase all push buttons with switch-on function or "D2" to erase all push buttons with switch-on/off function.

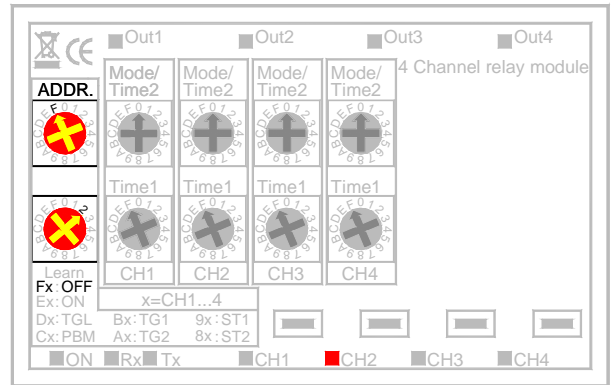

- Hold the manual command for channel 2 pressed until the relay is activated (see LED OUT2). Release the push button to erase all learned push buttons of the selected function from the module

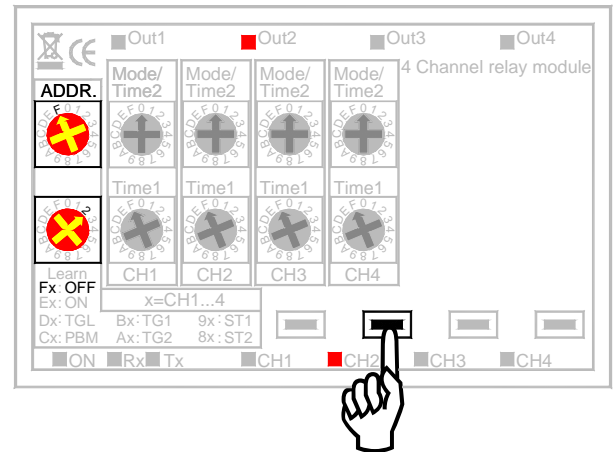

Some versions of the relay module allow you to erase all learned push buttons in one action. To do so, hold the manual push button pressed for 10 seconds. The relay will activate and then deactivate after 7 seconds. The deactivation indicates that all learned push buttons for channel 1 have been erased.

Erase all push buttons groups separately if the relay has not deactivated.

Set the address on "E2" and press the manual command until the relay activates. The push buttons with switch-on function for channel 1 are now erased.

Repeat this for addresses "D2", "C2", "B2", "A2", "92" and "82".

- Reset the original address of the relay module on "01". The "Mode2" LED (CH2) on the relay module and the indication LED will turn off.

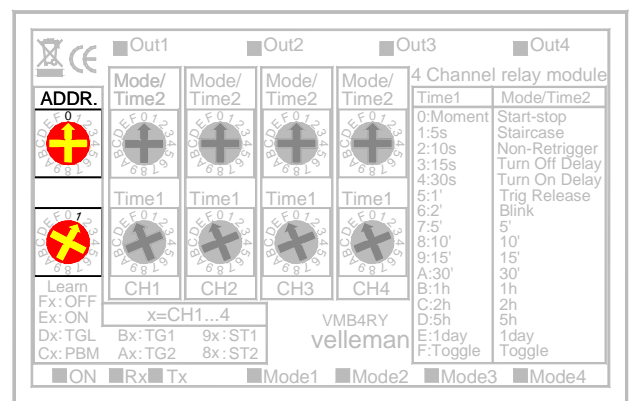

Erasing all learned push buttons from channel 3 in the relay module

- Set the relay module address on F3 to erase the push buttons with switch-off function. The "Mode3" LED (CH3) will blink.

Tip: To erase another push button group, select the learning address of that group. Example: "E3" to erase all push buttons with switch-on function or "D3" to erase all push buttons with switch-on/off function..

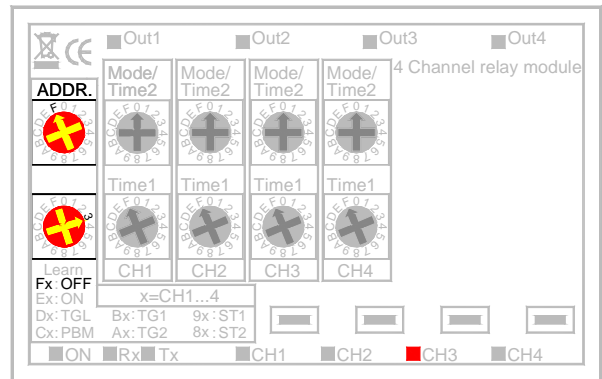

- Hold the manual command for channel 3 pressed until the relay is activated (see LED OUT3). Release the push button to erase all learned push buttons of the selected function from the module.

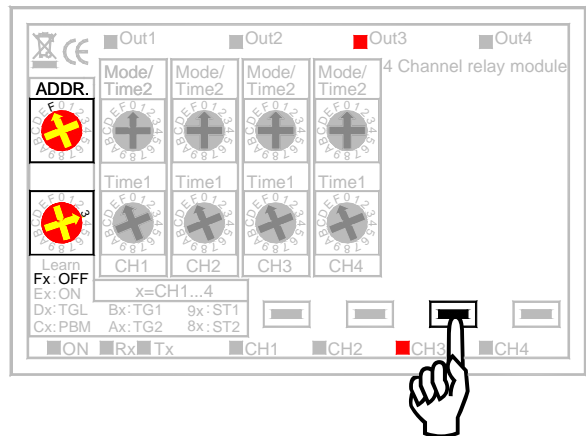

Some versions of the relay module allow you to erase all learned push buttons in one action. To do so, hold the manual push button pressed for 10 seconds. The relay will activate and then deactivate after 7 seconds. The deactivation indicates that all learned push buttons for channel 1 have been erased.

Erase all push buttons groups separately if the relay has not deactivated.

Set the address on "E3" and press the manual command until the relay activates. The push buttons with switch-on function for channel 1 are now erased.

Repeat this for addresses "D3", "C3", "B3", "A3", "93" and "83".

- Reset the original address of the relay module on "01". The "Mode3" LED (CH3) on the relay module and the indication LED will turn off.

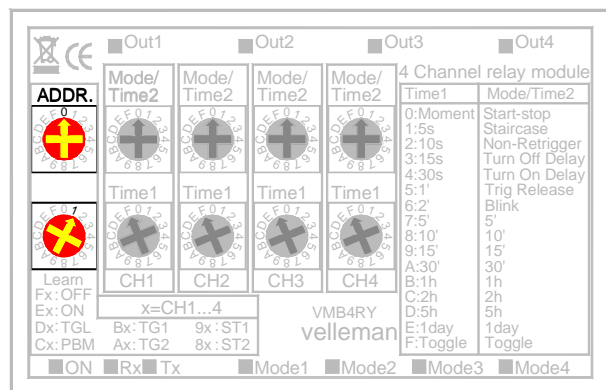

Erasing all learned push buttons from channel 4 in the relay module

- Set the relay module address on F4 to erase the push buttons with switch-off function. The "Mode4" LED (CH4) will blink.

Tip: To erase another push button group, select the learning address of that group. Example: "E4" to erase all push buttons with switch-on function or "D4" to erase all push buttons with switch-on/off function.

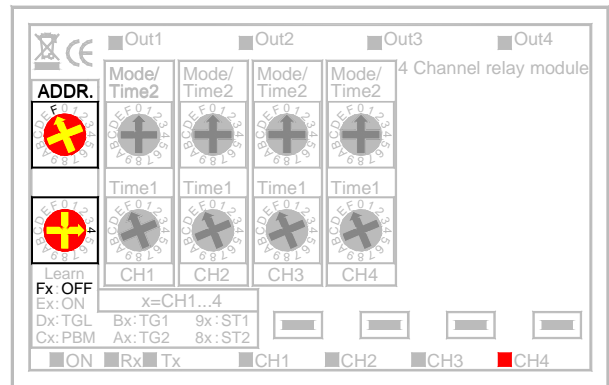

- Hold the manual command for channel 4 pressed until the relay is activated (see LED OUT4). Release the push button to erase all learned push buttons of the selected function from the module.

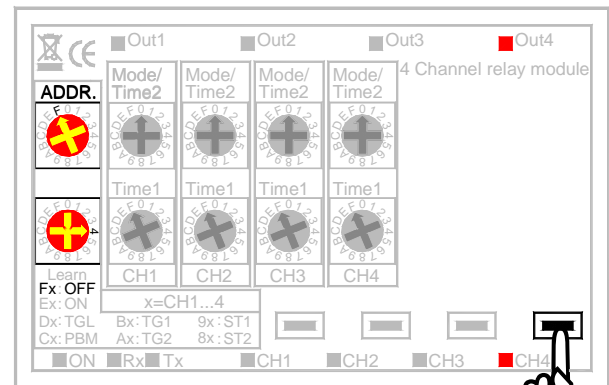

Some versions of the relay module allow you to erase all learned push buttons in one action. To do so, hold the manual push button pressed for 10 seconds. The relay will activate and then deactivate after 7 seconds. The deactivation indicates that all learned push buttons for channel 1 have been erased.

Erase all push buttons groups separately if the relay has not deactivated.

Set the address on "E4" and press the manual command until the relay activates. The push buttons with switch-on function for channel 1 are now erased.

Repeat this for addresses "D4", "C4", "B4", "A4", "94" and "84".

- Reset the original address of the relay module on "01". The "Mode4" LED (CH4) on the relay module and the indication LED will turn off. Close the relay module.

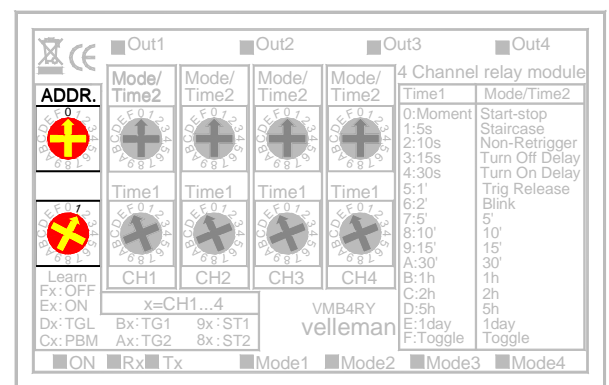

Velleman Home Automation System

Velleman[®] is a major distributor of electronic products and components and has its own R & D department. Velleman[®] is market leader in electronic kits with offices all over the world.



The Velleman building is powered by the Velbus Home Automation System.



In-house training & demonstration facility.

