

EDU
velleman[®]-kit 

EDUCATIONAL LCD OSCILLOSCOPE

FR KIT D'OSCILLOSCOPE ÉDUCATIF - AFFICHEUR LCD
NL EDUCATIEVE LCD-OSCILLOSCOOPKIT
DE OSZILLOSKOP-LERNPAKET - LCD-DISPLAY
ES KIT EDUCATIVO CON OSCILLOSCOPIO - PANTALLA LCD

EDU08



DISCOVER THE
WORLD OF ELECTRONICS

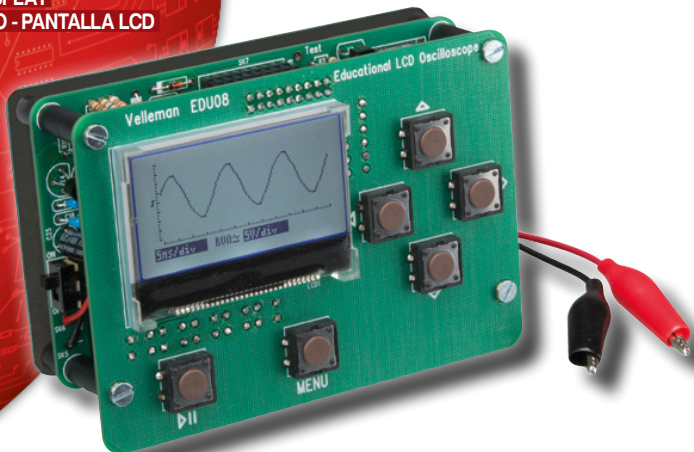

WWW.VELLEMANPROJECTS.EU



Velleman N.V.
Legen Heirweg 33
9890 Gavere
(België)



Velleman Projects
we build the hardware and
instrumentation kits, modules,
instruments and home automation

Selected language -
English (UK)

Change

Search product



Search Product

Velleman Projects Newsletter

Are you an electronic enthusiastic or simply interested in our kits, modules, modules and instrumentation?
Subscribe to our Newsletter and receive every month the latest build, new products & updates on Velleman Projects.

You will receive an email. Click on the link in that email to confirm your subscription.

Email:

NEW HX183 LED CUBE

Cubesat-motor software
available for download
today!

Posted on 04 Dec 13

[Read more...](#)

Do you want to unsubscribe? Click on the "unsubscribe" link in the footer of the last received newsletter from Velleman Projects.

Navigation

- Home page
- Products
- Sales outlets
- Support
- Publications
- Jobs
- About us

Items

Advertisements

- velleman.eu
- topower.eu
- parit.eu
- vellemanprojects.com
- velleman-project.com
- velleman
- forum.velleman.eu

Advertisements

- [ESP8266 / Arduino Android Application](#)



Subscribe to our newsletter?, visit www.vellemanprojects.eu



Need support? Check our Velleman Projects Forum



Velleman Projects



INSTRUMENTS
KITTING
and
KILL

Support Forum (ENFR)

Velleman Projects

123456789101112131415161718192021222324252627282930313233343536373839404142434445464748495051525354555657585960616263646566676869707172737475767778798081828384858687888990919293949596979899100

View unanswered posts | View all posts

Search titles

Message	Topics	Replies	Views	Last visit
General				
Introduction - Requirements for Kit Need for a USB programmer kit. Moderator: Velleman Support		3	3	Wed Dec 18, 2013 2:24 pm Velleman AD
Forum Administration Velleman - Database Kit - Dependencies Moderator: Velleman Support		4	4	Fri Nov 23, 2012 12:24 pm Velleman AD
Software				
Velleman Website Submitter Need an action for my new website home automation system (pending) Moderator: Velleman Support		404	2052	Fri Nov 23, 2012 1:04 pm Velleman AD
Kits (Building projects - Projects in progress)				
Arduino For arduino boards, generalisation and module, new ideas. Moderator: Velleman Support		235	432	Wed Dec 18, 2013 2:27 pm Velleman AD
Arduino & Projects All arduino related projects, amplifiers, video amplifiers Moderator: Velleman Support		897	2480	Fri Nov 24, 2012 6:02 pm Velleman AD
AVR Based Projects For projects that are programmed in the AVR like AVRISP and AVRISP-PRO Moderator: Velleman Support		403	2040	Fri Nov 24, 2012 6:02 pm Velleman AD
Microcontroller Programmer - Experimenting Projects Here you can discuss I2C programming, interrupts, etc. Moderator: Velleman Support		407	2140	Fri Nov 24, 2012 4:07 pm Velleman AD
Home Control Kits All about our "home control" projects from regular checks to programmable things. Moderator: Velleman Support		23	302	Fri Nov 24, 2012 6:02 pm Velleman AD
Hardware Kits Velleman's related products, from high accuracy remote control Moderator: Velleman Support		426	2283	Fri Nov 24, 2012 12:03 pm Velleman AD

Build your own oscilloscope and learn how to visualize signals. See the signals you learn about in real life! Despite the low cost, this oscilloscope has a lot of features found only on expensive units like signal markers, frequency, dB, true RMS readouts,... A powerful auto-setup function will get you going in a snap!

Note: This scope cannot be used to perform measurements on voltages higher than 30Vpp.



Educational



Input sensitivity range: in 6 steps,
100mV/division to 5V/division.



Timebase range: in 15 steps,
10µs/division to 500ms/division.



Input coupling: DC and AC.



Full auto set up for: Volt/div and time/div
(or manual).



Time and voltage markers readout.



Readouts: DC, AC+DC, true RMS, dBm,
Vpp, min. & max.



Battery operated: 4 x AAA batteries
(max. 100mA).



Maximum input voltage: 30Vpeak
(AC + DC).



LED backlight LCD.



Maximum sample rate: 1MS/s for repetitive
signals. Measurements can be performed
up to 100kHz.



Dimensions:
80 x 115 x 40mm / 3.14 x 4.52 x 1.57"

assembly hints

1. Assembly (Skipping this can lead to troubles !)

Ok, so we have your attention. These hints will help you to make this project successful. Read them carefully.

1.1 Make sure you have the right tools:

- A good quality soldering iron (25-40W) with a small tip.
- Wipe it often on a wet sponge or cloth, to keep it clean; then apply solder to the tip, to give it a wet look. This is called 'thinning' and will protect the tip, and enables you to make good connections. When solder rolls off the tip, it needs cleaning.
- Thin raisin-core solder. Do not use any flux or grease.
- A diagonal cutter to trim excess wires. To avoid injury when cutting excess leads, hold the lead so they cannot fly towards the eyes.
- Needle nose pliers, for bending leads, or to hold components in place.
- Small blade and Phillips screwdrivers. A basic range is fine.

☞ For some projects, a basic multi-meter is required, or might be handy.

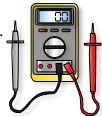

1.2 Assembly Hints :

- Make sure the skill level matches your experience, to avoid disappointments.
- Follow the instructions carefully. Read and understand the entire step before you perform each operation.
- Perform the assembly in the correct order as stated in this manual.
- Position all parts on the PCB (Printed Circuit Board) as shown on the drawings.
- Values on the circuit diagram are subject to changes, the values in this assembly guide are correct*.
- Use the check-boxes to mark your progress.
- Please read the included information on safety and customer service.

* Typographical inaccuracies excluded. Always look for possible last minute manual updates, indicated as 'NOTE' on a separate leaflet.

1.3 Soldering Hints :

1. Mount the component against the PCB surface and carefully solder the leads. →

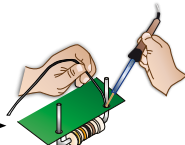

2. Make sure the solder joints are cone-shaped and shiny. →

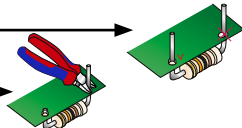

3. Trim excess leads as close as possible to the solder joint.

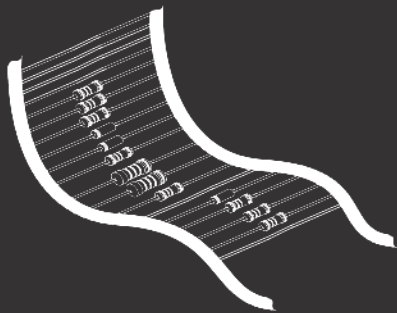

REMOVE THEM FROM THE TAPE ONE AT A TIME !

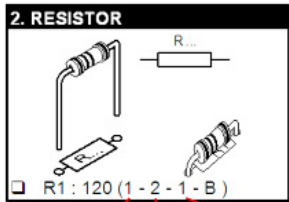

COLOR	COLOR NAME	1ST DIGIT/ STRIPE	2ND DIGIT/ STRIPE	3RD DIGIT/ STRIPE	MULTIPLIER STRIPE	TOLERANCE
Black	BLACK	0	0	0	x1	1%
Brown	BROWN	1	1	1	x10	
Red	RED	2	2	2	x100	
Orange	ORANGE	3	3	3	x1.000	
Yellow	YELLOW	4	4	4	x10.000	
Green	GREEN	5	5	5	x100.000	
Blue	BLUE	6	6	6	x1.000.000	

DO NOT BLINDLY FOLLOW THE ORDER OF THE COMPONENTS ON THE TAPE. ALWAYS CHECK THEIR VALUE WITH THE PARTS LIST!

A. CONSTRUCTION

This educational LCD oscilloscope consists of three parts: the base PCB, the display PCB and the rear panel. First we assemble the display pcb and then the base PCB. On the display module we mount components on both sides. We start at the solderside and finish with the components on the component side.

Display PCB

Solderside

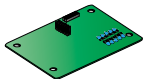

1 Vertical resistors

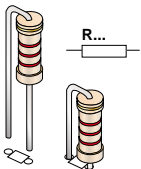

- R1 : 220Ω (2 - 2 - 1 - B)
- R2 : 560Ω (5 - 6 - 1 - B)
- R3 : 1KΩ (1 - 0 - 2 - B)
- R4 : 1K1 (1 - 1 - 0 - 1 - 1)*
- R5 : 2K4 (2 - 4 - 0 - 1 - 1)*
- R6 : 10KΩ (1 - 0 - 3 - B)

* metallfilm resistor !

2 Ceramic Capacitors

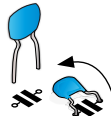

- C1 : 1μF (105)
- C2 : 1μF (105)
- C3 : 1μF (105)
- C4 : 1μF (105)
- C5 : 1μF (105)
- C6 : 1μF (105)
- C7 : 1μF (105)
- C8 : 1μF (105)
- C9 : 1μF (105)
- C10 : 1μF (105)

Bend the ceramic capacitors

3 Female header

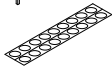
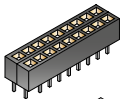

- SK1 : 18pins

Component Side

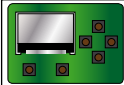

1 Push buttons



- SW1
- SW2
- SW3
- SW4
- SW5
- SW6

2 LCD

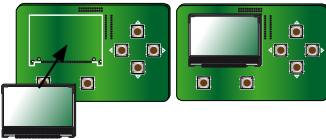

Be careful when soldering the LCD connections. Overheating will damage the LCD screen.

Base PCB

1 Diodes

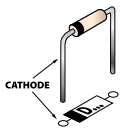

- D1 : BAT85
- D2 : BAT85
- D3 : BAT85
- D4 : BAT85
- D5 : BAT85
- D6 : BAT85
- D7 : BAT85
- D8 : BAT85

Watch the polarity!

2 Zenerdiode

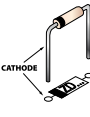

Watch the polarity!

- ZD1 : 5V1

3 Ceramic Capacitors



- C11 : 100nF (104)
- C12 : 100nF (104)
- C13 : 100nF (104)
- C14 : 100nF (104)
- C15 : 100nF (104)
- C16 : 100nF (104)

4 IC-socket

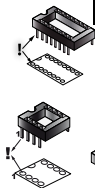

Watch the position of the notch!

- IC1 : 16p
- IC2 : 8p
- IC3 : 28p

5 Switch



- SW1 : on/off



6 Coil

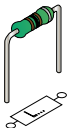

- L1 : 100 μ H (1 - 0 - 1 - B)

7 Trimmer



- RV1 : 5K (Gain)
- RV2 : 5K (Offset)

8 Ceramic Capacitors

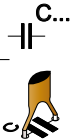
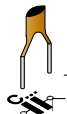

- C1 : 2,2pF (2.2)
- C2 : 6,8pF (6.8)
- C3 : 10pF (10)
- C4 : 15pF (15)
- C5 : 47pF (47)
- C6 : 100pF (101)
- C7 : 470pF (471)
- C10 : 680pF (681)

- C17 : 1 μ F (105)
- C18 : 1 μ F (105)
- C19 : 1 μ F (105)
- C20 : 1 μ F (105)
- C21 : 1 μ F (105)

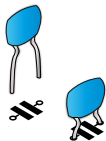

9 Vertical resistors

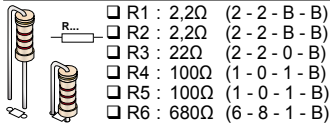

- R7 : 680Ω (6-8-1-B)
 R8 : 680Ω (6-8-1-B)
 R9 : 1KΩ (1-0-2-B)
 R10 : 1KΩ (1-0-2-B)
 R11 : 1KΩ (1-0-2-B)
 R12 : 1KΩ (1-0-2-B)
 R13 : 1K1 (1-1-0-1-1)*
 R14 : 1K5 (1-5-2-B)
 R15 : 1K5 (1-5-2-B)
 R16 : 2K2 (2-2-2-B)
 R17 : 2K7 (2-7-2-B)
 R18 : 5K1 (5-1-0-1-1)*
 R19 : 7K5 (7-5-0-1-1)*
 R20 : 10KΩ (1-0-3-B)
 R21 : 10KΩ (1-0-3-B)
 R22 : 10KΩ (1-0-3-B)
 R23 : 10KΩ (1-0-3-B)
 R24 : 11K (1-1-0-2-1)*
 R25 : 15K (1-5-3-B)
 R26 : 18K (1-8-3-B)
 R27 : 20K (2-0-0-2-1)*
 R28 : 22KΩ (2-2-3-B)
 R29 : 75K (7-5-0-2-1)*

* metallfilm resistor !

10 PCB tab

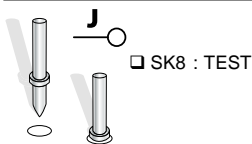

11 Transistors

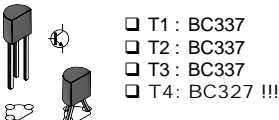

12 Voltage regulator



13 Relay

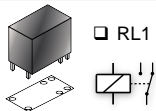

14 Electrolytic capacitors

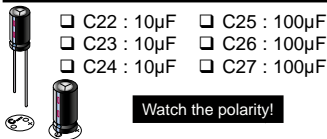

15 Male header

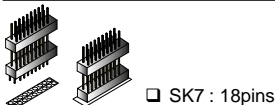

16 IC's

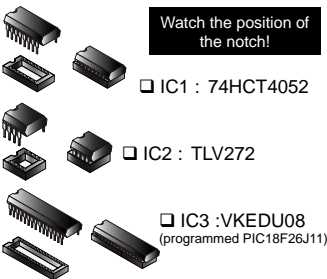

17 Mounting the test leads

STEP 1: Strip both cables and twist the wire ends of each cable.

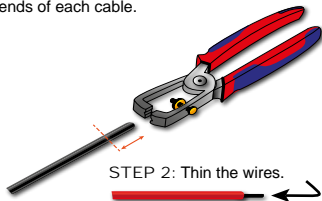

STEP 3: Mount both cables as shown in the drawing.

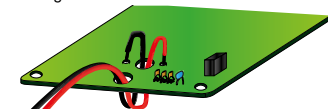

Tip: Start with one cable and then do the other.

Step 4: Solder the cables on the PCB.

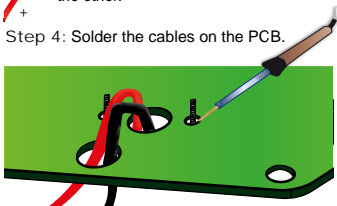

18 Mounting the battery holder

STEP 1: Stick one part of the included hook-and-loop strap (hooks) on one of the long sides of the battery holder.

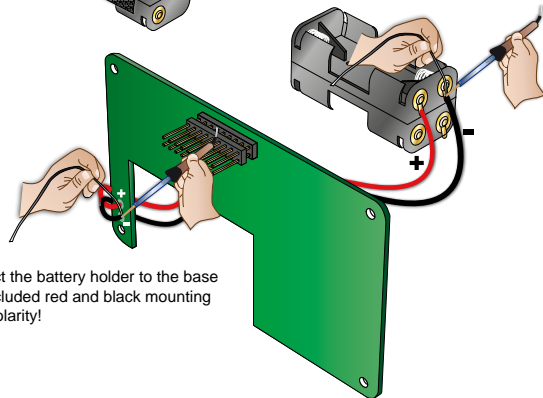
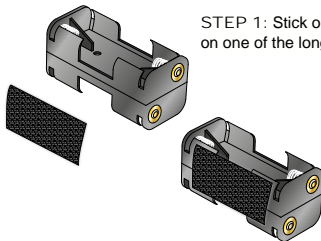

STEP 2: Connect the battery holder to the base PCB using the included red and black mounting wires. Mind the polarity!

- Red = +
- Black = -

B. ASSEMBLY

STEP 1: Place the base PCB on top of the backside of the cardboard cover and trace the opening on the cardboard.

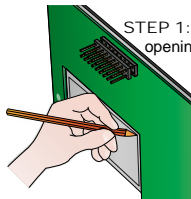

STEP 2: Stick the other part of the hook-and-loop strap (loops) in the centre of the traced area on the cardboard cover and put the parts together.

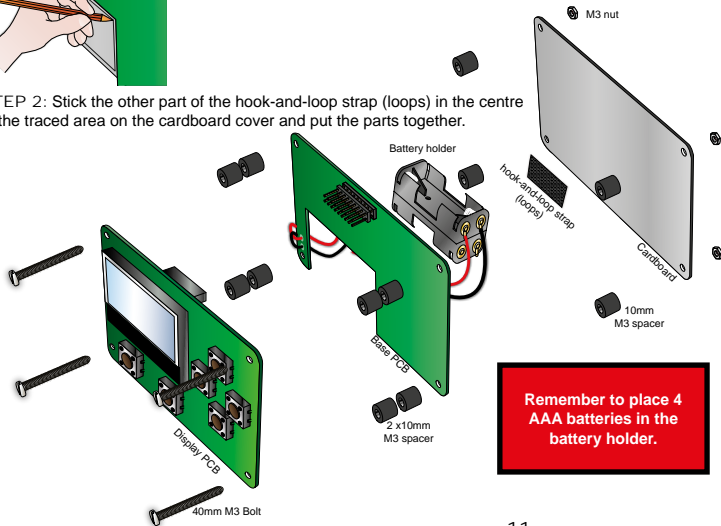

Remember to place 4 AAA batteries in the battery holder.

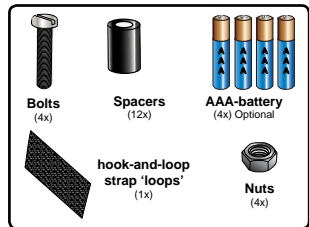
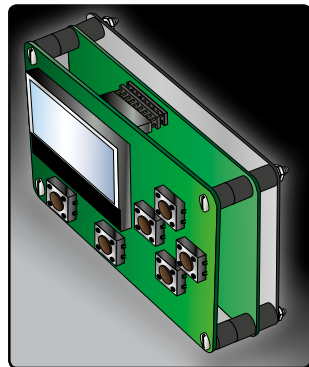

C. CALIBRATION

Fine tuning of the input amplifier circuit requires a 1.5V battery. This calibration is optional. You must only do this, if you want a higher precision of your measurements.

To adjust the "Offset" trimmer RV2:

- Connect the (+) of the test lead with the (-).



- Press the Menu button.
- Use the down arrow button to scroll down to "Measure".
- Use the right arrow button to select "Vdc".
- Press the Menu button to return to the oscilloscope display.
- Now adjust the Offset trimmer RV2 until the displayed value is 0.00V.

To adjust the "Gain" trimmer RV1:

- Measure the output of the battery with a multimeter and memorise it.
- Connect the battery to the oscilloscope's input.
- Adjust trimmer "Gain" RV1 until the displayed DC value corresponds with the measured value.
- Remove the battery.

If you had to adjust the Gain trimmer RV1 you have to check the offset trimmer RV2 setting again. Repeat these steps until both settings are OK.

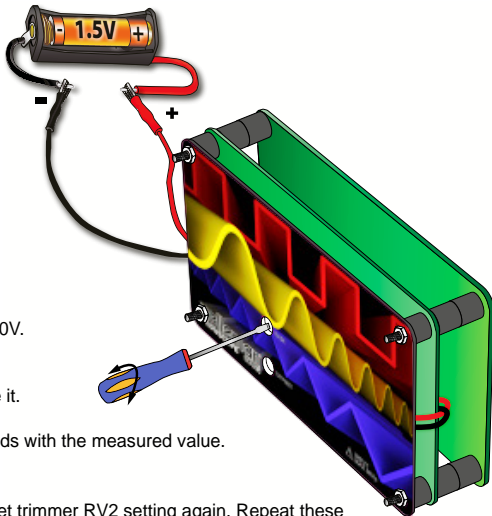

D. CONTROLS

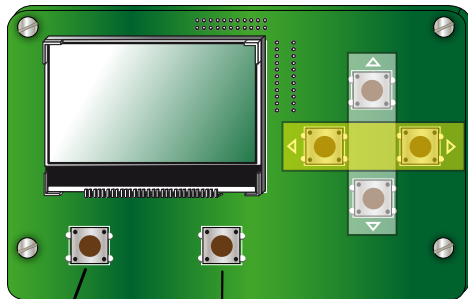

Run / Hold

Accepting the warning
&
Menu button

Volt/Div	AUTO	Volt
Time/Div	AUTO	time
Coupling	≈	DC
Trigger	AUTO	Trs
Trs Slope	/	Rising
Adjust	t-W/div	
Measure	None	
Markers	UI	tl,fl
Show	Time mark	
Run Mode	Run	
Contrast	5	
Eco Mode	On	

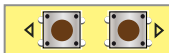

- Changing the volts/div.
- Changing the setup mode in the setup menu.
- Changing the position of the time markers during HOLD-mode.

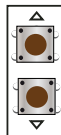

- Changing the timebase.
- Scrolling up/down in the setup-menu.
- Changing the position of the voltage markers during HOLD-mode.
- Changing the position of the trigger level during RUN-mode.

ON/OFF slide switch: Slide in the upper position to turn on unit.

- ⚡ Remark: To stretch the life of your batteries, the unit will turn off after approx. 10 minutes if left idle. Press any key to resume. If you do not want it to turn off automatically, you can select 'Eco mode OFF' in the menu (see further).

'Run'/'Hold'-button: When pressed, the unit toggles between 'Run'-mode and 'Hold'-mode.

'MENU'-button: Press once at turn-on to accept warnings. Press to enter or leave scope menu.

Up/Down/Left/Right buttons: To control the various functions of the scope, which are explained further in this manual.

E. TURN ON

At turn-on the splash screen below is displayed.

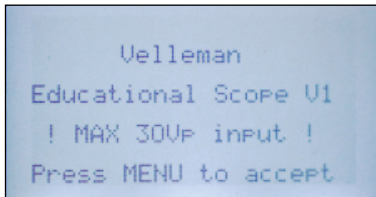

IMPORTANT! You should not attempt to measure voltages beyond 30Vp (=30VDC or 21VAC). If you are unsure if the voltage you're about to measure is within the limits of the scope, then don't measure it, or check with a multimeter first.

Also: Never attempt to perform measurements on equipment that is powered from the AC grid without a transformer, e.g. old TV sets, tube equipment, light dimmer circuits, etc... Usually, battery operated equipment is safe.

F. SCREEN LAYOUT

1. Vertical divisions. There are 8 vertical divisions.
2. Trigger level and trigger slope.
3. Time/division setting. When displayed in reverse video, automatic time/division setting is active
4. Indicates whether the scope is in 'RUN'- or in 'HOLD'-mode.
5. Input coupling (AC or AC+DC)
6. Volts/division setting. When displayed in reverse video, automatic volts/division setting is active
7. Horizontal divisions. There are 12 horizontal divisions.
8. Measurements will be displayed here, when selected
9. Trace. The graphical representation of the signal at the input of your scope. When there is nothing connected to the input of the scope, the trace is more or less flat and centered.

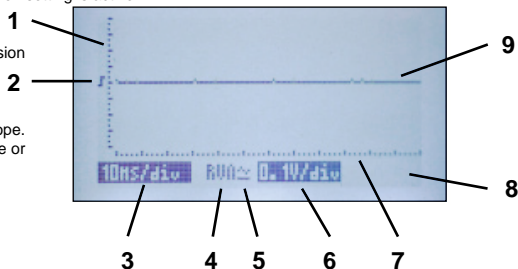

G. THE TEST PIN

Connect the RED alligator clip to the pin marked 'Test'.

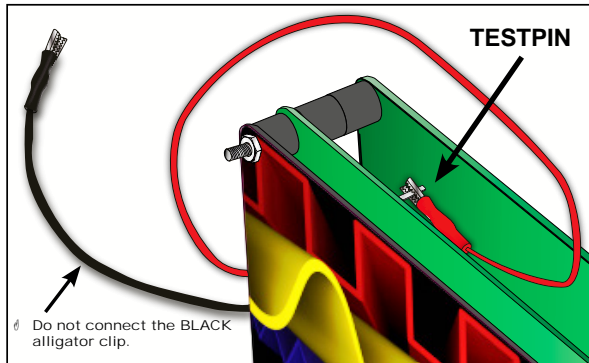

If your scope is working correctly, you should see a square wave displayed:

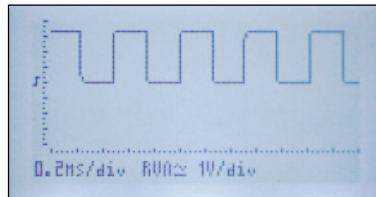

The test pin provides a square wave output with a frequency of approximately 2kHz (2000Hz).

Note that the volts/div and time/div settings have automatically changed, to ensure a correct visualisation of the signal.

H. THE MENU

Press the MENU button to display the menu:

Page 1:

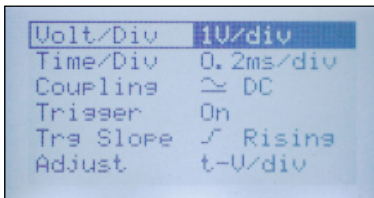

Page 2:

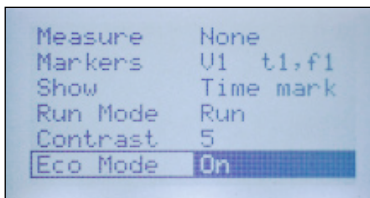

UP and **DOWN** arrow buttons allow you to scroll through all menu items on page 1 and 2.

LEFT and **RIGHT** arrow buttons allow you to change the settings.

Press **MENU** button again to leave menu and enable your selection.

MENU ITEMS:

Volt/Div: Select the appropriate V/div setting.

Available settings are:

AUTO Volt	(The unit automatically selects correct V/div setting)
0.1V/div	(Full screen range: 0.8V)
0.2V/div	(Full screen range: 1.6V)
0.5V/div	(Full screen range: 4V)
1V/div	(Full screen range: 8V)
2V/div	(Full screen range: 16V)
5V/div	(Full screen range: 40V)*

**(Note: safety requirements limits max. input voltage to 30Vp)*

Time/Div: Select the appropriate Time/Div setting.

Available settings are:

AUTO time	(The unit automatically selects correct Time/div setting)
10µs/div	5ms/div
20µs/div	10ms/div
50µs/div	20ms/div
0.1ms/div	50ms/div
0.2ms/div	100ms/div
0.5ms/div	200ms/div
1ms/div	500ms/div

Coupling:

Select the desired input coupling:

- **AC:** Only the AC-component of the signal is displayed
- **DC:** Both the AC and the DC component of the signal is displayed

Trigger:

Turn on or off the trigger function.

(Note: When AUTO Volt and/or AUTO time is selected, triggering is also set to AUTO Trg).

- **ON:** The unit will trigger when the signal reaches the set trigger level and when the slope corresponds with the selected slope.
- **OFF:** The unit will not trigger on a specific level. This is also called 'free running'. The displayed signal will not be stable.

Trg Slope (Trigger Slope): Select the edge of the signal on which the scope will trigger.

- **Rising:** Trigger when the signal level rises when it reaches the trigger level.
- **Falling:** Trigger when the signal level drops when it reaches the trigger level.

Adjust:

Choose the function of the up/down arrow keys:

- **t-V/div:** up/down/left/right arrow keys set Volt/div and time/div.
- **Trg Level:** up/down arrow keys set trigger level.

Measure: Select the desired readout, which is displayed in the lower righthand corner of the display. Available readouts are:

None:	Do not display a value
Vdc:	Display the level of the DC component of the signal
Vac:	Display the level of the AC component of the signal
Vac+dc:	Display the level of the complete signal
Vpk-pk:	Display the peak to peak level of the signal
Vmax:	Display the maximum level of the signal
Vmin:	Display the minimum level of the signal
dBm:	Display the level expressed in dB with respect to the reference: 0dB=0.775Vrms

Markers: Select the markers you wish to control with the arrow keys:
Choose between V1 t1,f1 or V2 t2,f2

Show:

Select the vertical marker readout:

- **Time mark:** Display time between the 2 vertical markers
- **Freq mark:** Display the frequency in Hz of the part of the signal between the 2 vertical markers

Run Mode: Choose how the screen will be updated

- **Run:** The screen is continuously updated.
- **Single:** The screen is only updated once.

Every time the 'Run/Hold'-button is pressed, the screen is updated

Contrast: Set the contrast of the screen

Range: 1..7 (1: low contrast, 7: high contrast)
Default: 5

Eco Mode:

- **On:** The LCD backlight and the input coupling relay is turned off when the unit is left idle for approx. 10 minutes, to reduce battery drain. Press any key to resume.

(Note: There is still a drain of about 40mA, even when Eco Mode is ON, so make sure to turn off the unit when not in use).

- **Off:** The eco mode is disabled.

I. LET'S MEASURE

Measuring DC voltage: Measuring a 9V battery (not incl.)

First, make sure that your scope is properly calibrated (see page 12).

- Turn on the scope.
- Connect the alligator clips to the battery. Mind the polarity.
- Connect the red clip to the (+) of the battery and the black clip to the (-) of the battery.

You should see something like this:

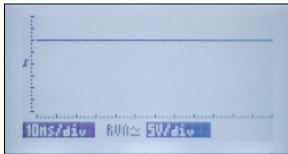

A 9V battery generates a DC voltage, that explains the flat line. Look closely at the number of vertical divisions, the trace almost reaches the second division and the volts/div setting is 5V/div, so the measured voltage is a little less than 2x5V or 10V.

How much is the exact voltage supplied by our battery?

Open the menu, scroll down to Measure and select Vdc.

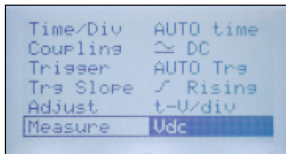

Leave the menu and watch the lower right hand corner:

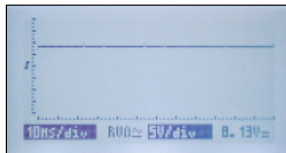

Our 9V battery supplies 8.13VDC

Now, swap both alligator clips and check what happens:

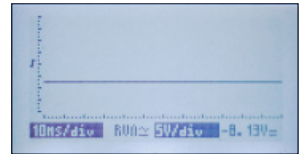

This is a nice feature of an oscilloscope, it can measure both positive and negative DC voltages.

Displaying and measuring waveforms:

We have a nice waveform available at the test pin, it is perfect for our measurements.

Turn off the scope, connect the red alligator clip to the 'test'-pin and turn on the scope.

You should see something like this:

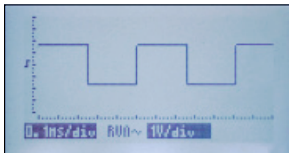

This is called a square wave. Note that the complete waveform is drawn above the center of the screen. This is because our waveform contains not only an AC but also a DC component:

Now, enter the menu and select '**AC coupling**' instead of '**AC+DC coupling**'

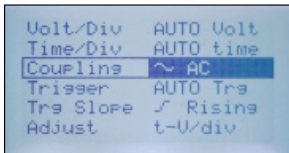

Now the position of the waveform changes, as the DC component of the signal is blocked.

The scope only displays the AC part, which is both positive and negative.

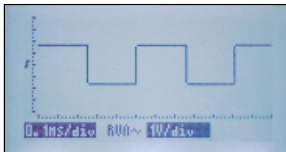

Let's measure the **frequency** and **period** of our waveform.

First, we turn on the markers, by pressing the 'HOLD'-button. Next, we isolate a single period of our waveform by moving both horizontal markers as shown below:

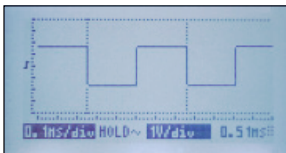

The lower right hand corner displays the period of our signal: 0.51ms. To display the frequency, we select:

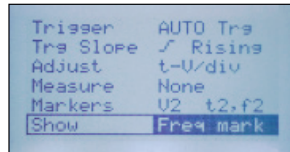

Now the scope will display the frequency of our signal:

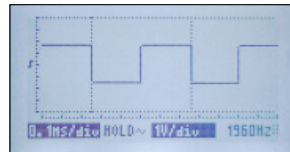

Note that there are also horizontal markers available. They allow us to measure e.g. the peak to peak value of our waveform, which is also displayed in the lower right hand corner.

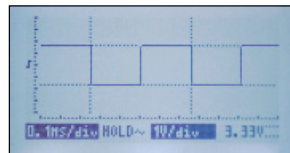

Triggering and how to use it:

Triggering helps us to get a stable trace on the screen and it also allows us to capture events.

When 'AUTO Volt' and 'AUTO time' is enabled, the scope triggers automatically.

To enable manual triggering, select 0.1ms/div and 1V/div from the menu and set Trigger to On:

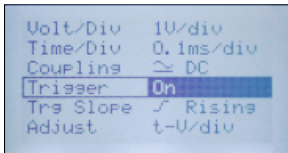

The display will look like this:

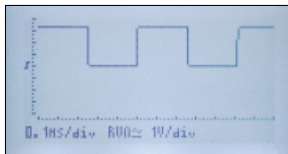

Before we can adjust the trigger level we have to change the function of the UP/DOWN keys from setting VOLT/Div to 'changing the trigger level':

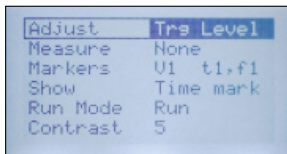

Now we can change the trigger level by pressing the UP or DOWN keys. The slope symbol also indicates the trigger level.

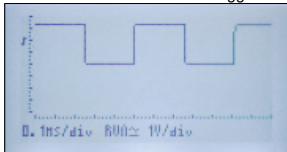

If you move the trigger level to the center position, the trace will become unstable, because it no longer triggers on a single point, but anywhere between a falling and a rising edge of the signal:

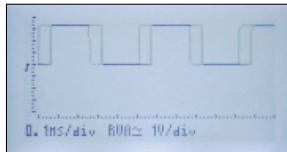

If you move the trigger level to a point lower than the signal, the scope will no longer refresh the trace, as the trigger level is no longer reached.

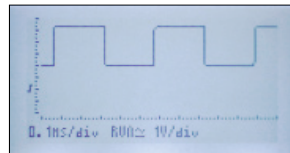

Now, lets change the slope:

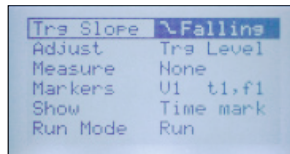

Look closely at the signal now (left), do you see the difference with the previous screenshot of our signal (right)?

Look closely at the signal now (left), do you see the difference with the previous screenshot of our signal (right)?

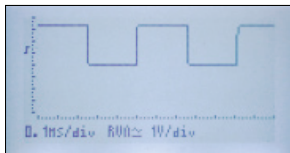
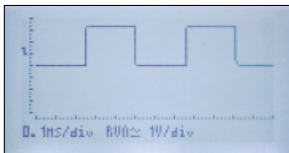

Single:

Sometimes, you would like to 'capture' a certain event, instead of continuously looking at a signal. This can be done by choosing 'Single' instead of 'Run' as the Run mode. The scope will start drawing the trace when the trigger level and slope are reached and when it reaches the right hand side of the screen, it will stop drawing and switch to 'HOLD'-mode. Press the 'HOLD'-button again to 're-arm' the trigger and wait for the next event to happen.

Try the following experiment:

- Disconnect the red alligator clip from the 'test'-pin.
- Turn the scope off and on again, so that all settings are set to default.
- Select following items from the menu: 0.1V/div, 0.1ms/div and Adjust Trg Level.

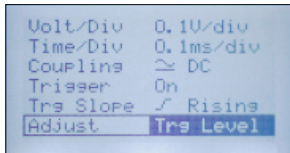

Next, leave the menu and set the trigger level as shown below:

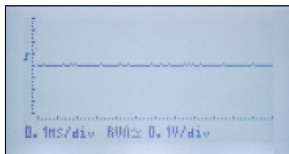

Enter the menu and select 'Single' as the trigger mode.

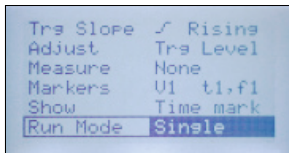

The display will look more or less like below:

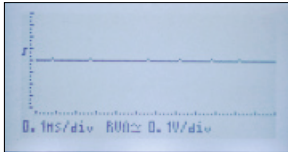

Now, touch the red alligator clip with your finger. Your body acts like an antenna and touching the clip will induce 'noise' to the input of the scope. The unit will trigger and the display will show a single screen of the noise you've injected through your finger. Next, the scope will switch to 'HOLD' mode. Now you have plenty of time to study the screen.

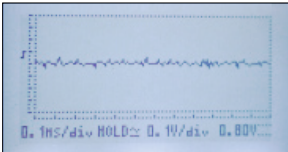

To capture the next event, press the 'HOLD'-button briefly.

Triggering is re-armed and when you touch the red alligator clip again, the screen will refresh:

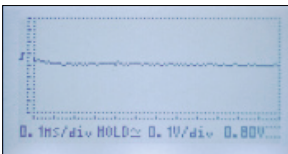

SO FAR FOR THE BASICS OF AN OSCILLOSCOPE. WE ENCOURAGE YOU TO FURTHER EXPERIMENT AND DISCOVER ALL FEATURES OF YOUR OSCILLOSCOPE.



Make sure to check out our EDU6 Oscilloscope tutor kit. It features lots of information and a number of experiments to familiarise yourself with the basics of an oscilloscope.

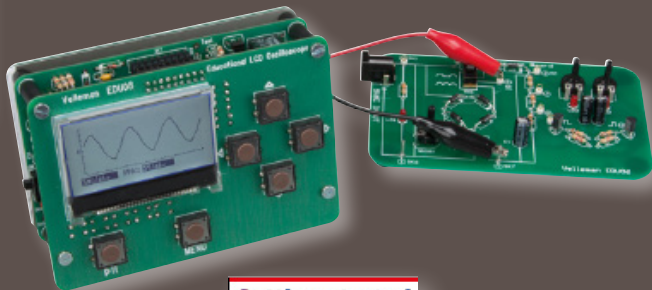

For more in-depth info about oscilloscopes in general, their features and their operation, check out this guidebook.
www.velleman.eu



Start to measure using your EDU08 oscilloscope. Learn all about its features and perform simple measurements. Recommended for novices.
www.velleman.eu

OSCILLOSCOPE TERMINOLOGY

1. **Volts/div:** Determines how many volts the signal at the input must swing for the trace to move one division.
2. **Time/div:** Determines the time the trace needs to scan from the the left hand side to the right hand side of a division.
3. **Division:** Imaginary or visible grid on the oscilloscope screen. It helps estimating signal amplitude and period.
4. **Period (T):** Duration of one cycle of the AC waveform ($= 1/f$).

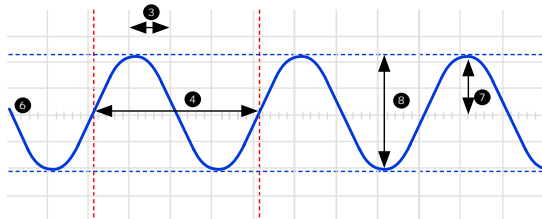

5. **Frequency (f):** The number cycles of the AC waveform per sec.
6. **Trace:** 'line' that is drawn on the screen, which represents the signal at the input.
7. **Amplitude:** How far does the signal 'swing' in a direction. Expressed in mV or V. For repetitive signals: V_{peak} .
8. **Peak-to-peak:** Difference between most positive and most negative swing of the signal. $2 \times V_{peak}$ for sinusoidal signals.

'AC coupling': The oscilloscope only displays the AC component of a signal, any DC level is ignored.

'AC voltage': (AC: Alternating Current) With AC, the flow of the current periodically reverses, as opposed to DC, where the current flows in one direction. An AC source does not have a polarity.

'Auto setup'-mode or Automatic Volts/div and/or time/div: The oscilloscope automatically selects a setting for Volts/div and Time/div in such a way that one or more periods of signal are displayed correctly.

Bandwidth: Usually expressed in MHz. It is the frequency at which an applied sine wave will be displayed at an amplitude of around 70% of its original amplitude. More expensive scopes feature a higher bandwidth. Rule of thumb: the bandwidth of an oscilloscope needs to be at least 5 times higher than the frequency of the signal applied to the input of the scope.

Clipping: When the 'top' or 'bottom' or both extremes of a signal are cut-off ('clipped'), e.g. because the signal cannot swing any further due to power supply limitations. An undesired property of amplifiers that are driven beyond their specs. Also happens when a too small Volt/div setting is selected or the signal the input of the scope is beyond the specs.

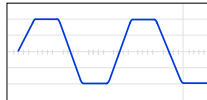

DC coupling: The oscilloscope displays both the AC and the DC component of a signal.

DC reference: DC measurement is always performed with respect to a ground level, so we need to define this ground level. If you do not set the DC reference, the readout might not be correct. In most cases, this ground level will be the center of the screen, however this is not mandatory.

DC voltage: (DC:Direct Current) With DC, the current flows in a single direction, it does not reverse. A DC source has a polarity, (+) and (-).

Digital: Digital scopes perform an analog to digital conversion on the incoming signal and handle all the calculations and displaying in the digital domain. Digital signals feature only two fixed levels, usually 0V and +5V. See also 'Analog'.

Distortion: Undesired alteration of a signal due to external causes such as overloaded circuits, badly designed circuits, etc...

Free running: When triggering is not enabled, then the unit is in free running mode. A trace is continuously drawn, but the signal will not be stable.

HOLD or HOLD mode: When HOLD mode is active, the screen is not longer updated. It allows you to have a closer look at the signal.

Input coupling: The drawing shows typical oscilloscope input circuit. There are 3 possible settings: AC-coupling, DC coupling and GND. With AC-coupling, a capacitor is put in series with the input signal. This capacitor blocks any DC component of the signal and passes only AC. With DC coupling, the capacitor is bypassed and both the AC and DC component of the signal are passed. Low frequency signals (<20Hz) should always be displayed using DC coupling. Should AC coupling be used, the internal coupling capacitor will interfere with the signal and the displayed signal will not be correct.

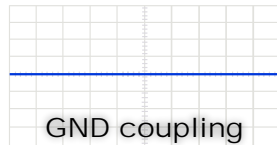
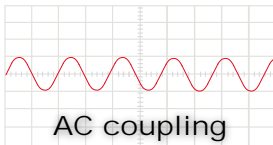
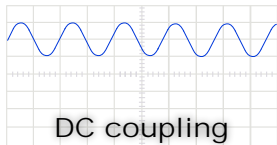

Noise: Undesired random addition to a signal.

Ripple: Unwanted periodic variation of a DC voltage.

Rising or falling slope: It determines where the scope will trigger. This can be on the rising or on the falling slope of the signal.



RUN or RUN-mode: When in RUN-mode, the screen is continuously updated with new data.

Sample rate: Usually expressed in samples or megasamples/second, sometimes in MHz. It is the number of times per second the digital oscilloscope 'looks' at the signal at the input. The more it 'looks', the better it is able to recreate a faithful image of the waveform on the screen. Theoretically the sample rate needs to be twice the max. frequency of the applied signal, however, for best results a sample rate of 5 times the max. frequency is recommended. The EDU08 samplerate is max. 1MS/s for repetitive signals, 100kS/s in real time.

Signal: Voltage applied to the input of the oscilloscope. The subject of your measurement.

Sine wave: Mathematical function that represents a smooth repetitive oscillation. The waveform shown at the start of this glossary is a sine wave.

Spikes: Fast, short duration transients in a signal.

Trigger: Triggering is a technique used to get a stable image on the screen. This is achieved by making sure that the scope always starts to draw the trace at the exact same point, represented by a certain level of the signal. By doing so, every waveform is drawn on top of the previous one and sideways scrolling of the trace is prevented.

Trigger level: Determines the level the signal has to reach before the scope triggers. By setting a certain trigger level, you can filter events and only display the events you want to display.

Vrms: The rms voltage of an AC source represents the required DC voltage to generate the same amount of heat in a resistor as the AC source would do. For sinusoidal signals, $V_{rms} = V_{peak} / \sqrt{2}$.

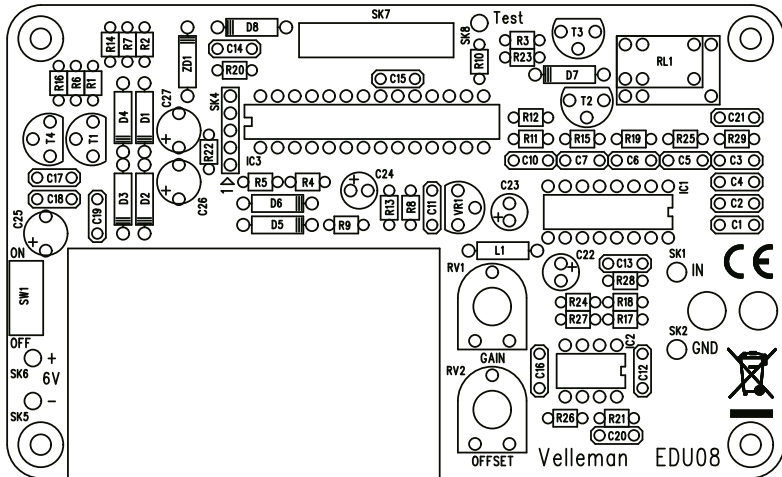

BASE PCB

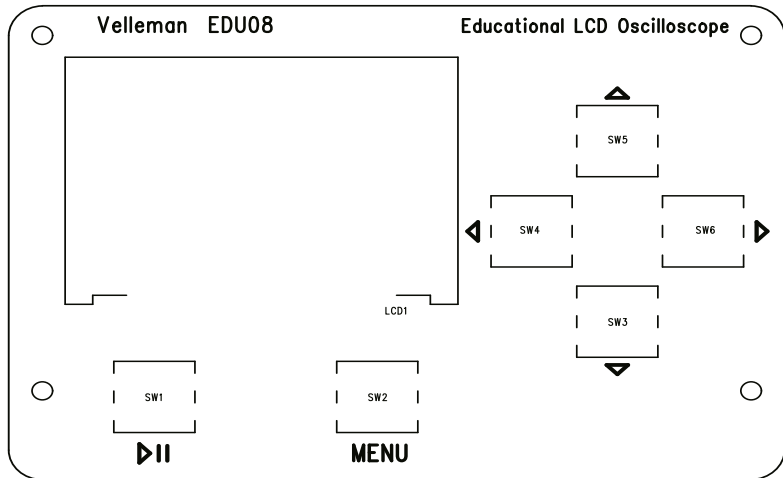

DISPLAY PCB

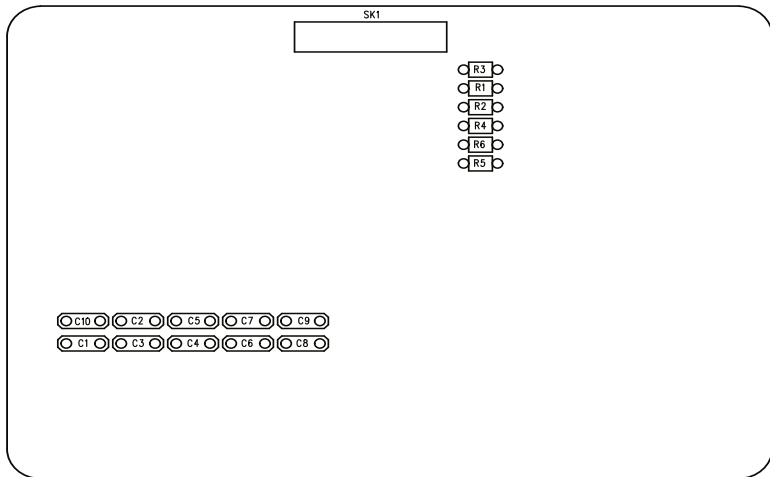

DISPLAY PCB

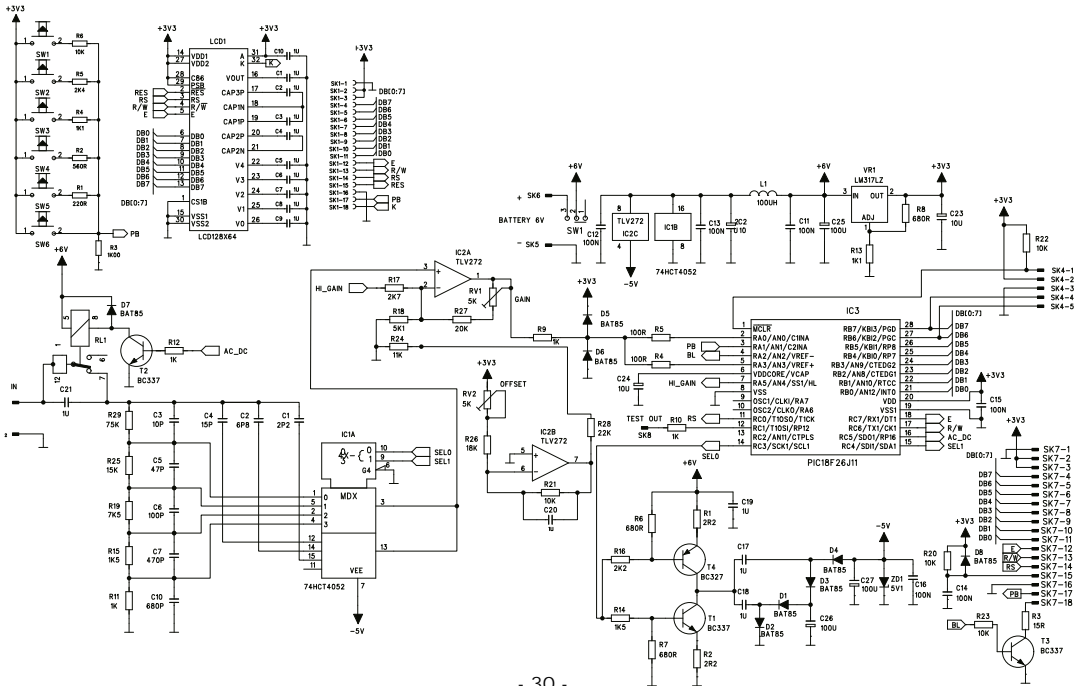

Leds and how to use them

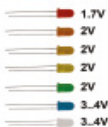

Leds feature a specific voltage drop, depending on type and colour. Check the datasheet for exact voltage drop and rated current !

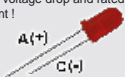

Never connect leds in parallel

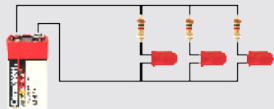
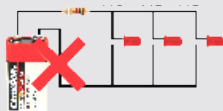

How to Calculate the series resistor:

Example: operate a red led (1.7V) on a 9Vdc source.

Required led current for full brightness: 5mA (this can be found in the datasheet of the led)

$$\frac{\text{Supply voltage (V) - led voltage (V)}}{\text{required current (A)}} = \text{series resistance (ohms)}$$



$$\frac{9V - 1.7V}{0.005A} = 1460 \text{ ohm}$$

closest value :
use a 1k5 resistor

Required resistor power handling=
voltage over resistor x current passed trough resistor



$$(9V - 1.7V) \times 0.005A = 0.036W$$

a standard 1/4W resistor
will do the job

LEDs in series:

Example: 3 x red led (1.7V) on 9V battery
Required led current for full brightness: 5mA
(this can be found in the datasheet of the led)

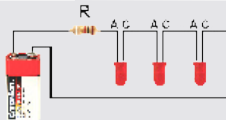

$$\frac{\text{Supply voltage (V) - (number of leds x led voltage (V))}}{\text{required current (A)}} = \text{series resistance (ohms)}$$



$$\frac{9V - (3 \times 1.7V)}{0.005A} = 780 \text{ ohm}$$

use an
820 ohm resistor

open collector outputs

An open collector output can be compared to a switch which switches to ground when operated

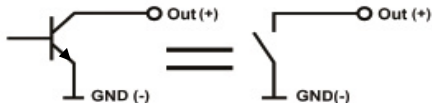

Example: How to switch an LED by means of an open collector output

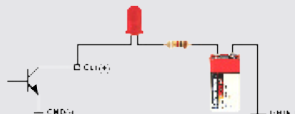

velleman®
projects

Velleman nv, Legen Heirweg 33 - 9890 Gavere (België)



Modifications and typographical errors reserved. © - HEDU08- 2013- ED1