

velleman®

VM130V2SET



Full Manual VM130V2SET

Contents

In the Box	2
Warnings	2
Overview	3
Mounting the Receiver	3
First Set-Up	4
Pairing a Transmitter to the Receiver	4
Connecting the Receiver to the TUYA IoT Cloud (optional).....	5
Connecting a Device to the Relays.....	8
Generating a new Code for the Transmitter.....	8
Clearing Transmitters from the Receiver Memory (Reset).....	8
Using the VM130V2SET with the Transmitter	9
Using the VM130V2SET with the TUYA App	10
Troubleshooting.....	19
LEDs and their meaning	19
Poor reception between transmitter and receiver.....	19
Bad reception between the receiver and the TUYA IoT cloud.....	19
FAQ.....	20
Can I use the VM130V2SET with a previous version?.....	20
The TUYA function does not work when I move the receiver.	20
I can hear a click every time the channel switches.....	20
When I switch on the receiver, the relay switch without having used the transmitter.	20
Does the VM130V2SET work at the 5 GHz Wi-Fi frequency?	20
Can I modify the RF frequency (433 MHz)?	20
Can I buy a transmitter separately to pair to an existing VM130V2SET?	20
RED Declaration of Conformity.....	20

In the Box



A. Transmitter (VM130V2-T)

- 1x 8LR932 12V battery included
- RF 433 MHz operation < 10 dBm

B. Receiver (VM130V2-R)

- Input 12 VDC – 1 A
- RF 433 MHz operation < 10 dBm
- WLAN 2.4 GHz operation < 20 dBm
- μ T35

C. Power supply (PSS6E1210C1)

- 12 VDC – 1 A

Warnings

- *This VM130V2SET is suited for indoor use.*
- *The VM130V2SET cannot be used to operate machines.*
- *Replace the transmitter's battery if transmission becomes weak.*
- *Do not mount the receiver in the proximity of other electronic devices or metal objects to guarantee a good reception of the wireless signals.*
- *Always use fresh batteries before changing the code of the transmitter. Otherwise, the transmitter can be damaged.*
- *If you use another power supply than the one provided in the package, please check that the output specifications are 12 VDC - 1 A. Different specifications will damage the device permanently.*



Overview

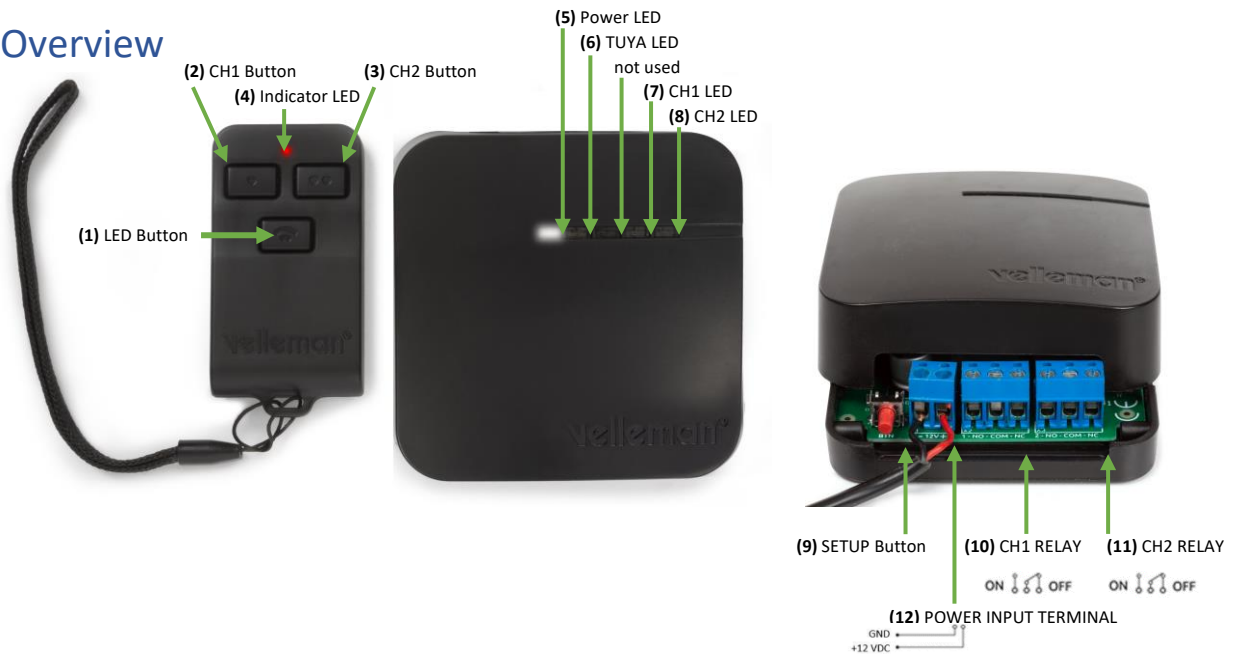

Mounting the Receiver



The receiver can easily be mounted against a wall or ceiling with the 2 mounting holes in the back of the case. The mounting holes have a diameter of 6,3 mm and the centre points are 62,9 mm apart from each other. Loosen the 2 Phillips screws on the two sides of the case to open the enclosure.

First Set-Up

Connect the receiver with the supplied power supply: position the bare wires into the power input terminal **(12)** on the board. The black (GND) wire goes into the “-” terminal, the red (+12VDC) wire goes into the “+” terminal. Use a flat screwdriver to tighten the screws of the terminals.

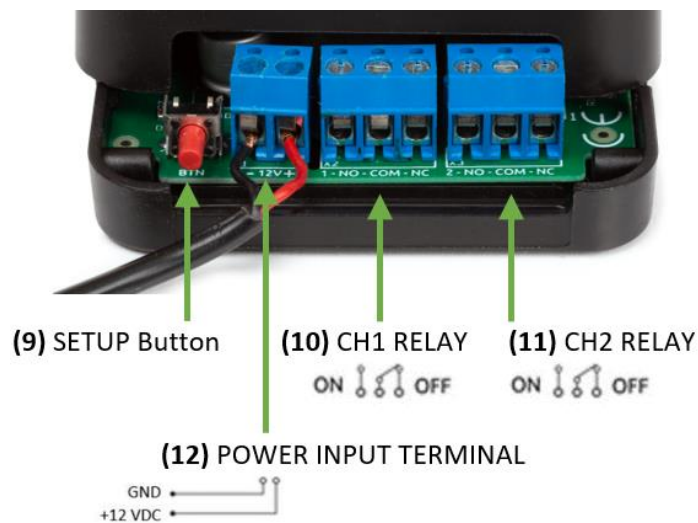

If the power supply is successfully connected, the power LED **(5)** will light up and the TUYA LED **(6)** will start flashing after a few seconds.

Please do not connect the CH1 RELAY and CH2 RELAY terminals **(10 & 11)** or close the enclosure yet. We first need to pair a transmitter or connect to the TUYA IoT cloud.

Pairing a Transmitter to the Receiver

1. Power off the receiver by disconnecting the power.
2. Make sure there are no connections to the receiver on CH1 RELAY and CH2 RELAY **(10 & 11)**.
3. Power on the receiver by connecting the power.
4. Hold the SETUP button **(9)** on the receiver for at least 3 seconds until the CH2 LED **(8)** will turn on.
5. Press the CH1 button **(2)** on the transmitter for 3 seconds until the CH2 LED **(8)** will turn off and the CH1 LED **(7)** will turn on.
6. The remote is now paired.

You can pair multiple transmitters with a single receiver. Keep following these steps for every transmitter you want to pair.

Connecting the Receiver to the TUYA IoT Cloud (optional)

1. Install the TUYA app or SmartLife app on your smartphone and create a TUYA account.

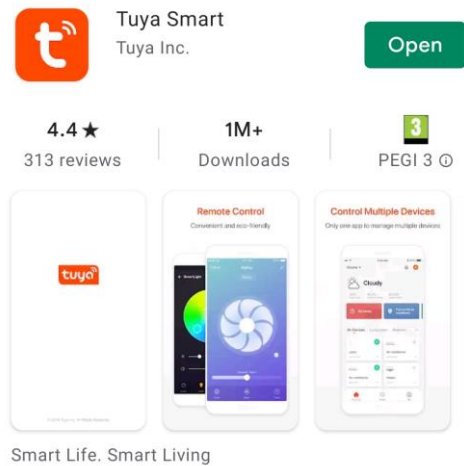

2. Make sure there is a stable Wi-Fi connection with internet access present where the receiver is installed. You will need the Wi-Fi password in step 8, so start looking for it now.



3. Power off the receiver by disconnecting the power.
4. Make sure there are no connections to the receiver on CH1 RELAY and CH2 RELAY **(10 & 11)**.
5. Push the SETUP button **(9)** on the receiver and hold it while connecting the power supply.
6. Release the SETUP button **(9)** after the CH1 LED **(7)** is activated. The SETUP button **(9)** can now be used for TUYA pairing.
7. Open the TUYA app or SmartLife app and add device “Power Strip (Wi-Fi)”.

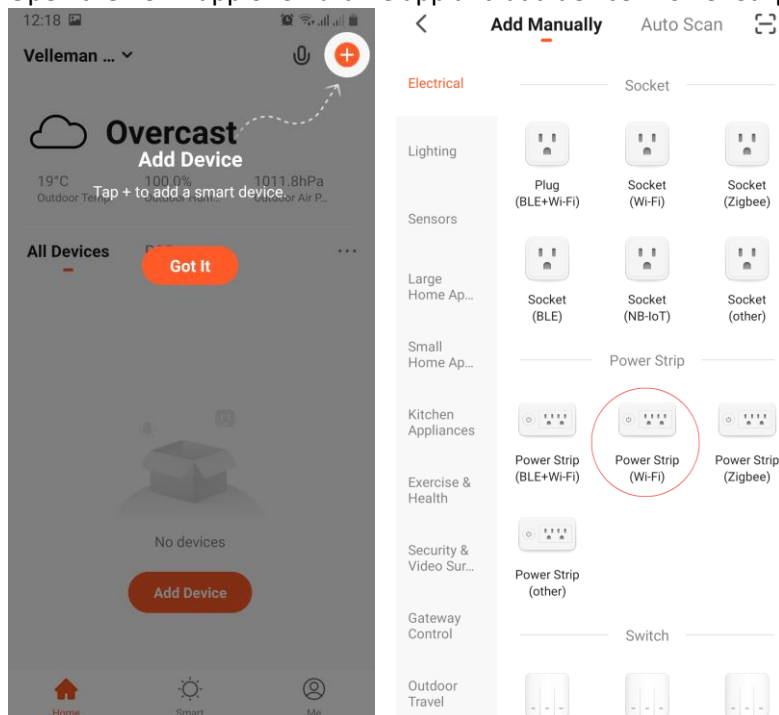

8. Select the network you wish to use for the VM130V2SET and enter the password for the W-Fi network. Attention: Make sure it is a 2.4 GHz network! The VM130V2SET does not work on a 5 GHz network.

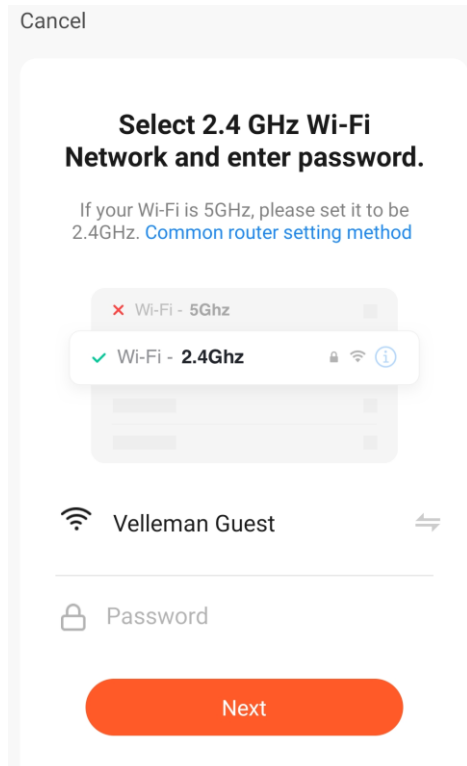

9. If the app asks to press the “reset” button, use the SETUP button (9). The TUYA LED (6) should start blinking rapidly when in pairing mode. Confirm with “Confirm the indicator is blinking rapidly”.

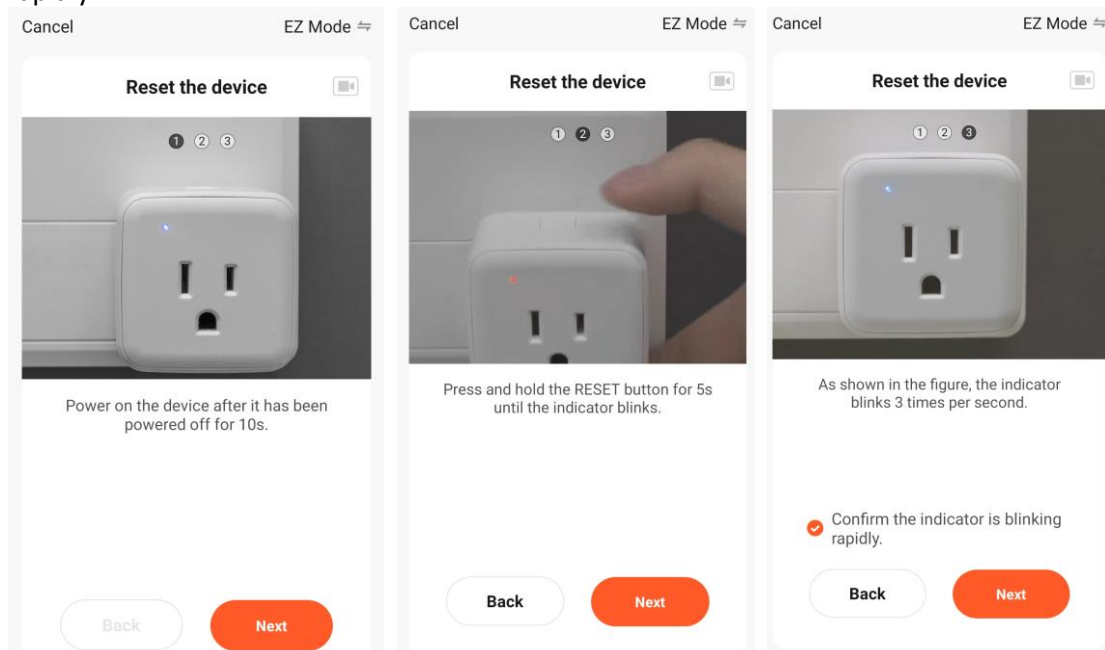

10. The device is now added to your TUYA account. You will immediately see the interface with both channels of the VM130V2SET. Press these buttons to make the corresponding channels on the receiver switch. If the device is successfully paired with the TUYA IoT cloud, the TUYA LED (6) be turned on permanently (see page 3). From now on, this TUYA LED (6) will display if there is an active cloud connection.

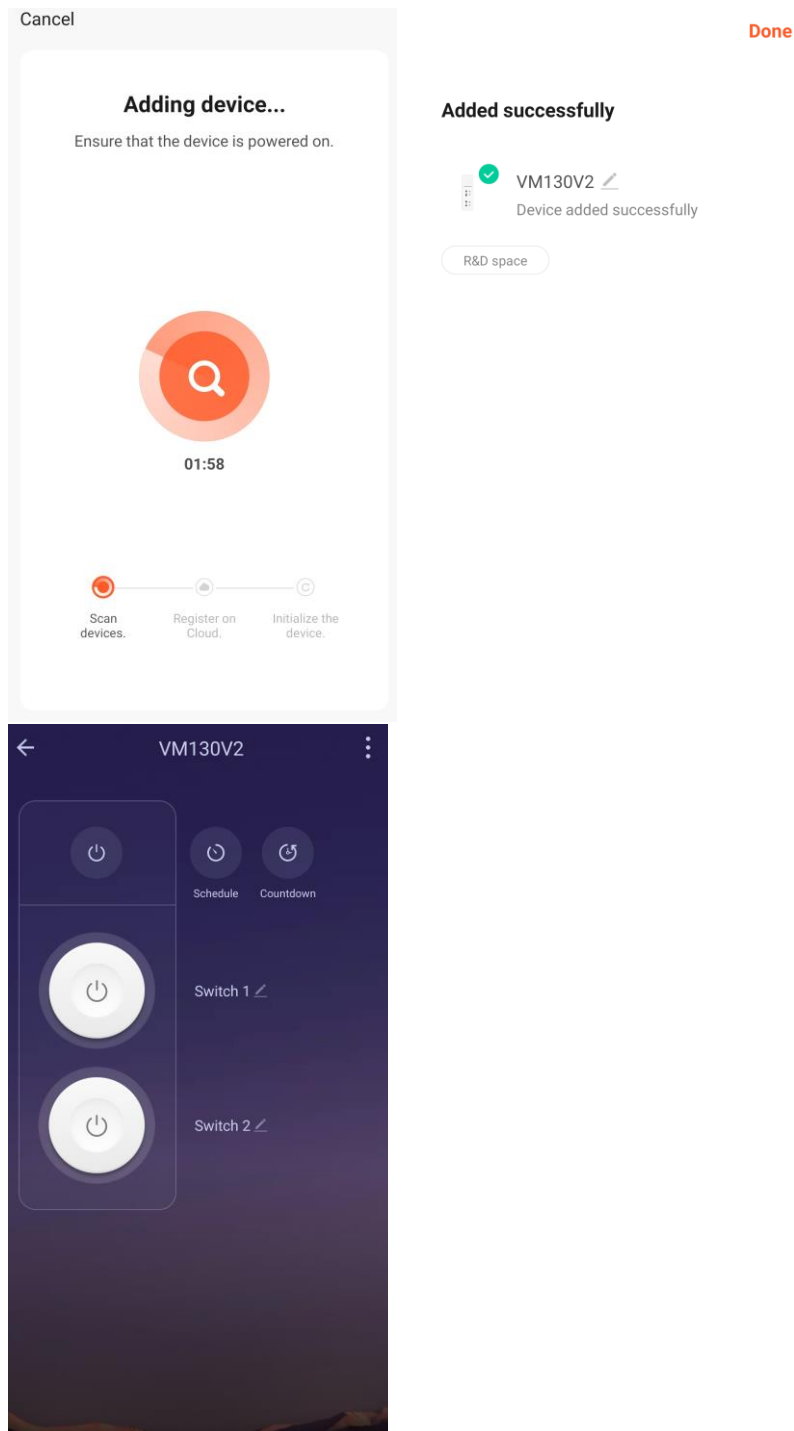

11. Please disconnect the power to the receiver, wait 3 seconds and reconnect the power. The device will boot in normal operation and you are ready to use it. It will automatically connect to the cloud.

Connecting the receiver with the TUYA IoT cloud is optional. If not connected to the cloud, the functionality of the VM130V2SET will be limited to ON/OFF functions for both channels with the transmitter.

Connecting a Device to the Relays

Connect your device to the receiver by using the NO (normal open) & COM (common) terminals of each channel (**10 & 11**) for standard off-mode. If you prefer standard on-mode, please use the NC (normal closed) & COM (common) terminals (**10 & 11**).

Please note that the relays are suited for max. 48 VDC operation on 5A (resistive load) each. Both channels are dry contacts (power needs to be supplied by another source).

Example 1: device with the same power supply voltage as the VM130V2SET with NC contacts

12 V LED strip connected to channel 1 on the NC (normally closed) and COM (common) terminals. The LED strip shares the power supply voltage of the power supply unit with the VM130V2SET. When connecting the schematic below, the LED strip will burn as long as channel 1 is off. When switching on channel 1 the LED strip will switch off.

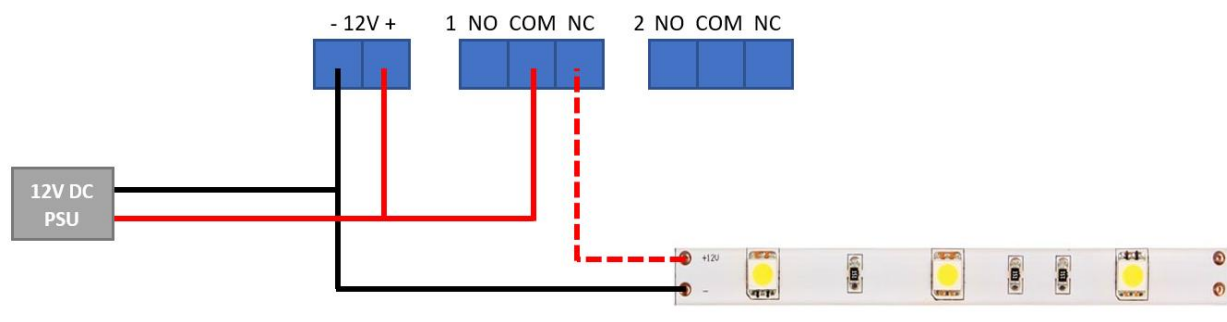

Example 2: device with different power supply voltage as the VM130V2SET with NO contacts

24 V LED strip connected to channel 2 on the NO (normally closed) and COM (common) terminals. The LED strip has its own power supply source. When connecting the schematic below, the LED strip will not burn as long as channel 2 is off. When switching on channel 2 the LED strip will switch on.

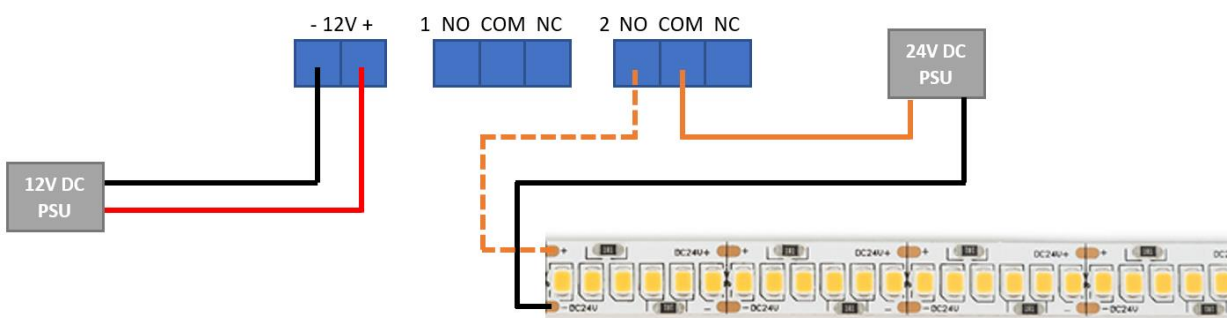

Generating a new Code for the Transmitter

Simultaneously hold the CH1 button (**2**) and CH2 button (**3**) on the transmitter for at least 5 seconds. The new code will be generated. After successful completion, the red indicator LED (**4**) on the transmitter will flash briefly.

Please note that you will need to re-pair the transmitter with the receiver after generating a new code for the transmitter.

Clearing Transmitters from the Receiver Memory (Reset)

1. Power off the receiver by disconnecting the power.
2. Make sure there are no connections to the receiver on CH1 RELAY and CH2 RELAY (**10 & 11**).
3. Power on the receiver by connecting the power.

4. Hold the SETUP button **(9)** on the receiver for at least 3 seconds until the CH2 LED **(8)** will turn on.
5. Again, hold the SETUP button **(2)** on the receiver for 3 seconds until the CH2 LED **(8)** will turn off.
6. All transmitters are now cleared from the receiver's memory.

Please note you will need to re-pair a transmitter to the receiver.

Using the VM130V2SET with the Transmitter

Press the CH1 button **(2)** on the transmitter for **minimum 2 seconds** to change the state of the CH1 relay **(10)** on the receiver. If the channel was on, it will turn off (and stay off). If it was off, it will turn on (and stay on).

Press the CH2 button **(3)** on the transmitter for **minimum 2 seconds** to change the state of the CH2 relay **(11)** on the receiver. If the channel was on, it will turn off (and stay off). If it was off, it will turn on (and stay on).

The red Indicator LED **(4)** on the transmitter will flash while you hold the CH1 button **(2)** or CH2 button **(3)**, indicating transmitting a signal. After 3 seconds, the transmitting will stop automatically to save the battery.

The receiver shows the status of each channel with the CH1 LED **(7)** and the CH2 LED **(8)**. LED on= channel active. LED off = channel deactivated.

Press the LED button **(1)** to use the flashlight functionality of the transmitter.

Using the VM130V2SET with the TUYA App

This requires an internet connection on your smartphone and a good Wi-Fi connection to the receiver.

1. Open the TUYA app or SmartLife app on your smartphone and select the “Power Strip” device.
2. You will see the state of both channels. Press a channel to change its state (ON/OFF – OFF/ON).

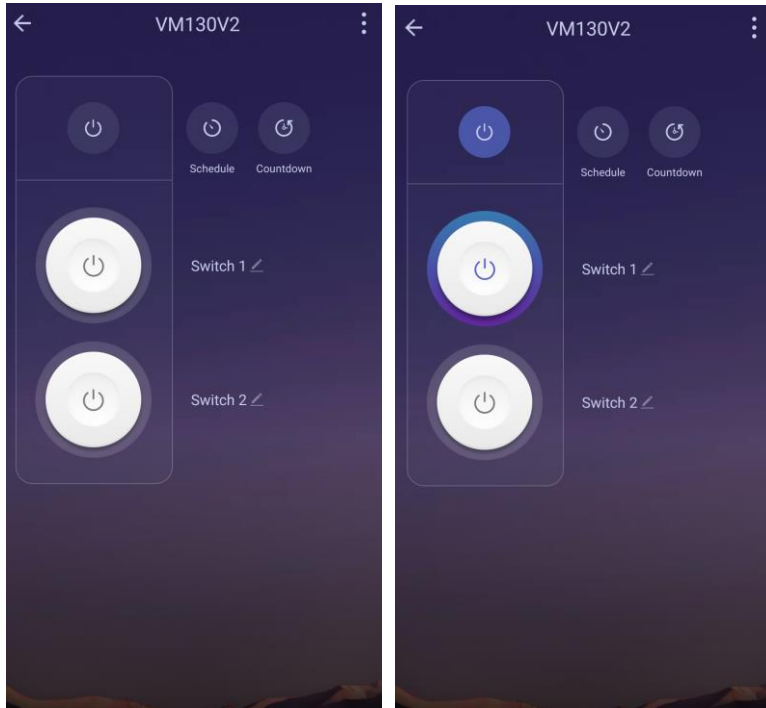

3. Use the ‘CountDown function’ to use a countdown timer for a specific channel (you can select a time that you want the channel to turn off or on).

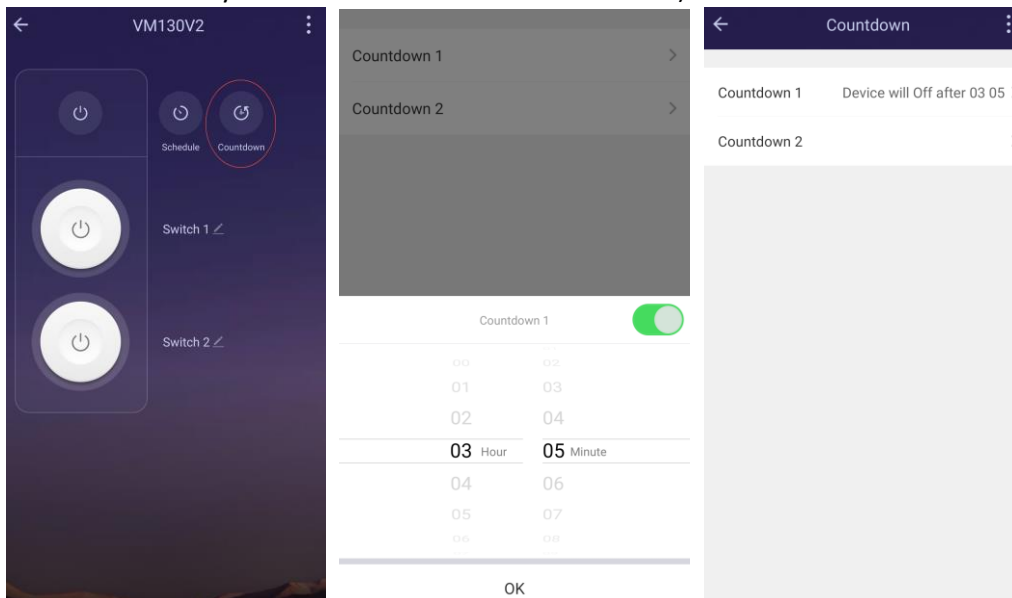

4. Use the 'Schedule function' to add multiple times during the day or week when you want each individual channel to turn on or off. Determine when it must be repeated with the "Repeat" option.

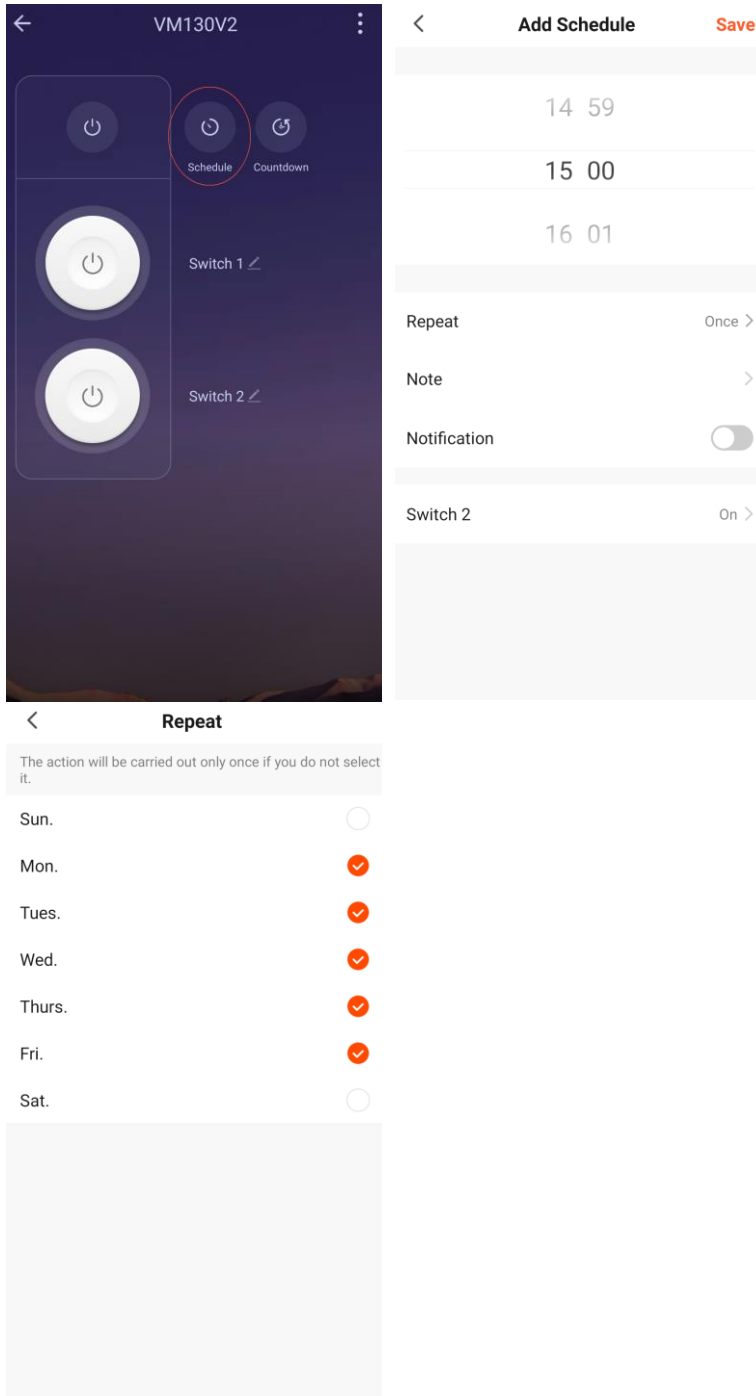

5. Add every channel onto you wish to switch a channel with the “Add Schedule” button.

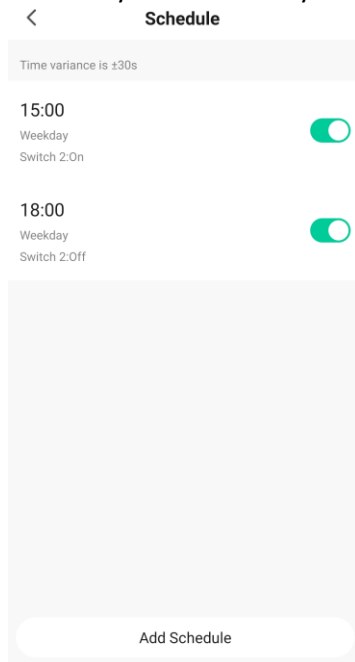

6. By using the “Smart” tab in the app, you can specify several actions that will control the channels.

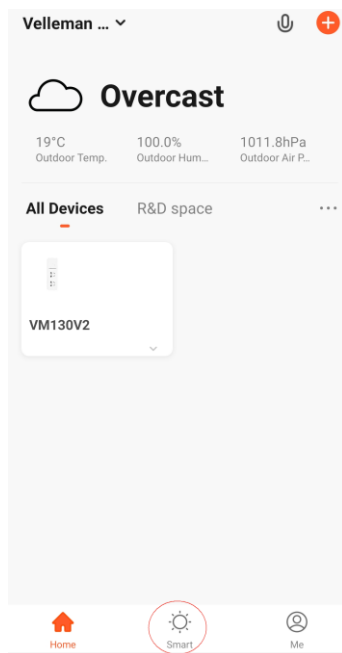

Example 1: Switching a channel based on the sunrise

In this example, we will create a smart action based on “When weather changes”. We choose the input “Sunset/Sunrise”.

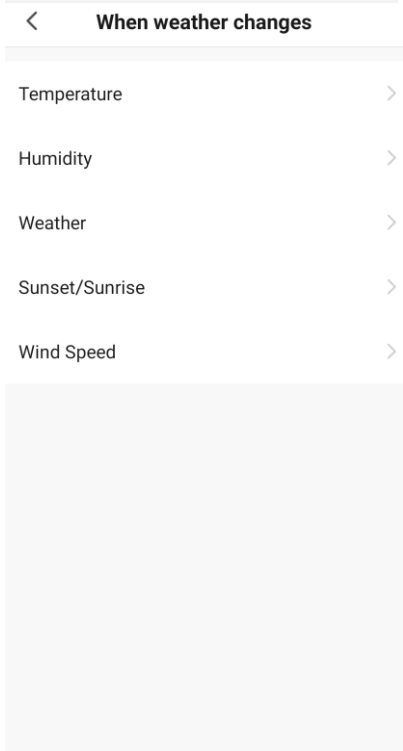
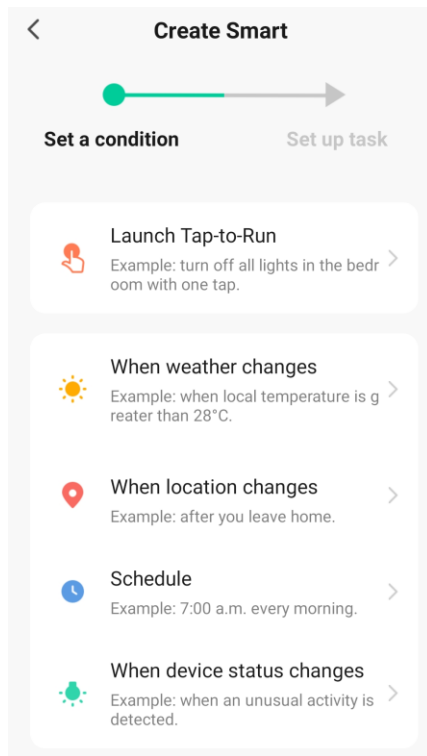
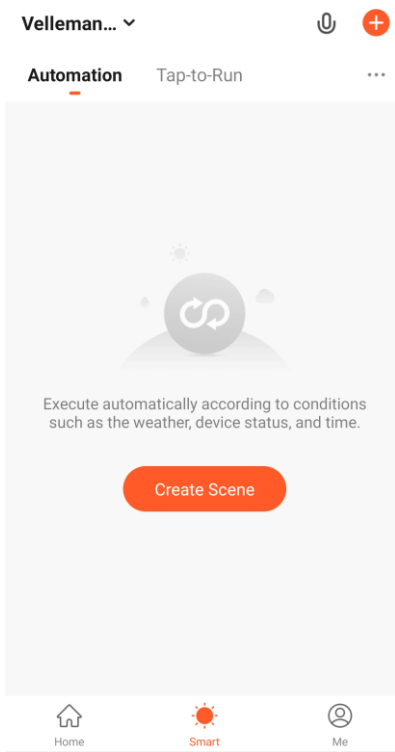

In the next step, we select our location and the specific moment when we wish to switch. After choosing the input, we then select the “Run the device” action and choose for the VM130V2.

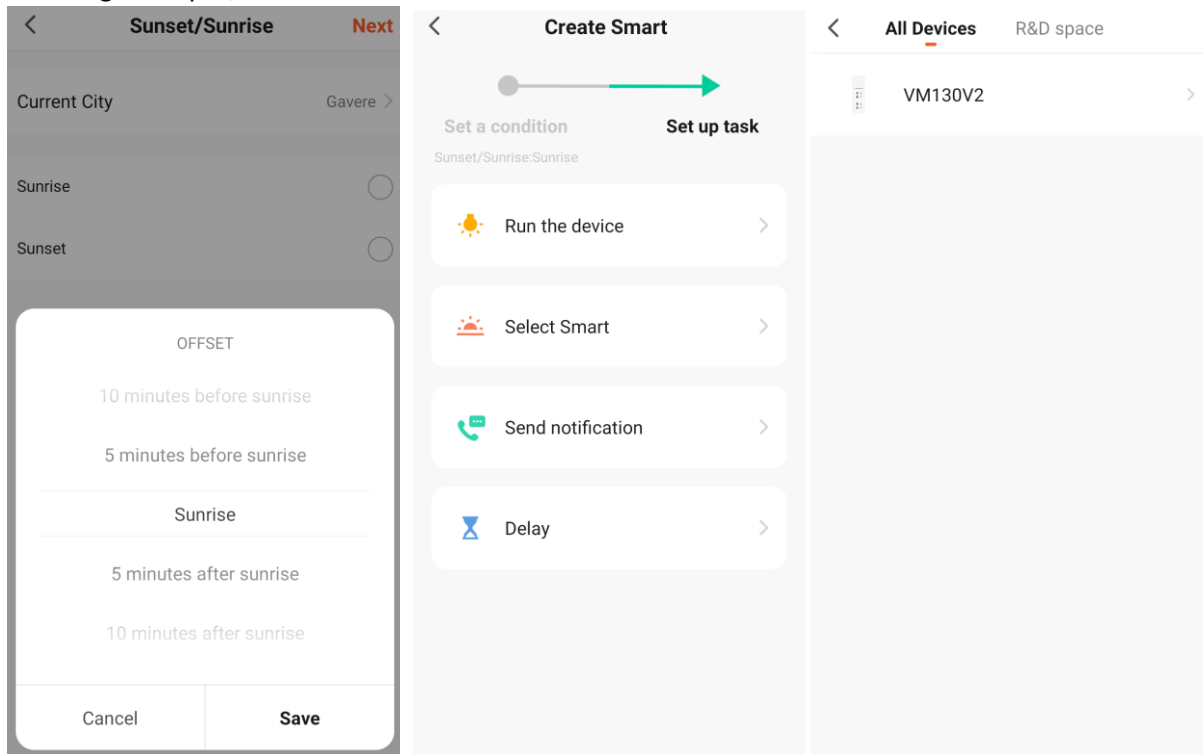

Now, we select the desired channel we wish to switch at sunrise, in this case channel 1 (Switch 1). Select the ‘ON’ option. Finally, we have an overview of the selected parameters. Click on 'Save'. From now on, channel 1 will switch at sunrise. You can always activate/deactivate this smart action via the ‘Smart’ tab.

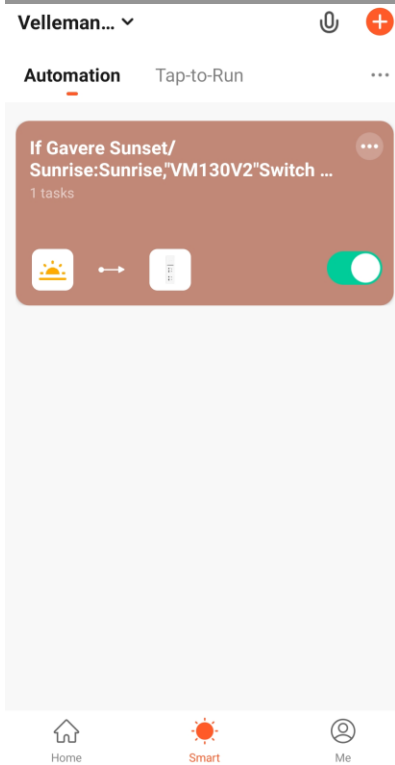
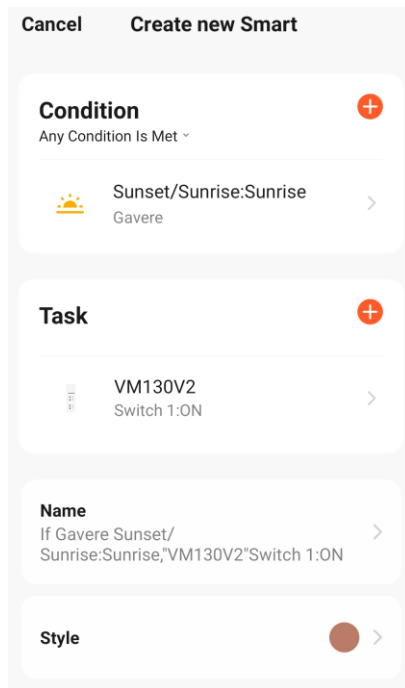
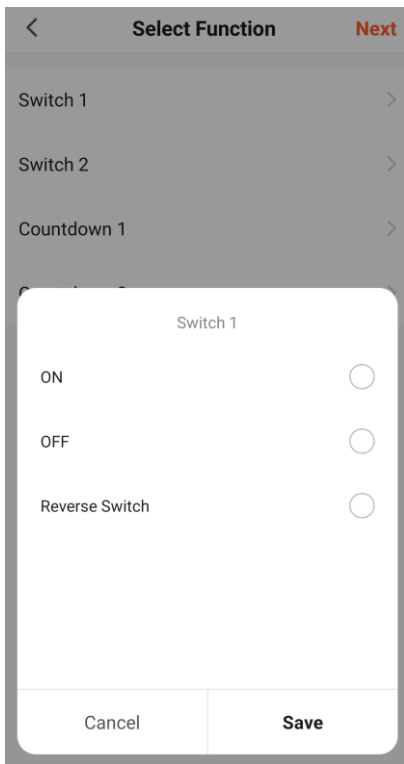

Example 2: Making a channel 'pulse'

In this example we want channel 1 to act as a 'pulse' contact. In other words, when the channel switches, it will switch back automatically after a set time. This function is interesting to switch a garage door, which only needs a short 'on' signal.

We create a new smart action via the 'Smart' tab, with "When device status changes" as condition. We select the VM130V2 and channel 1 (Switch 1).

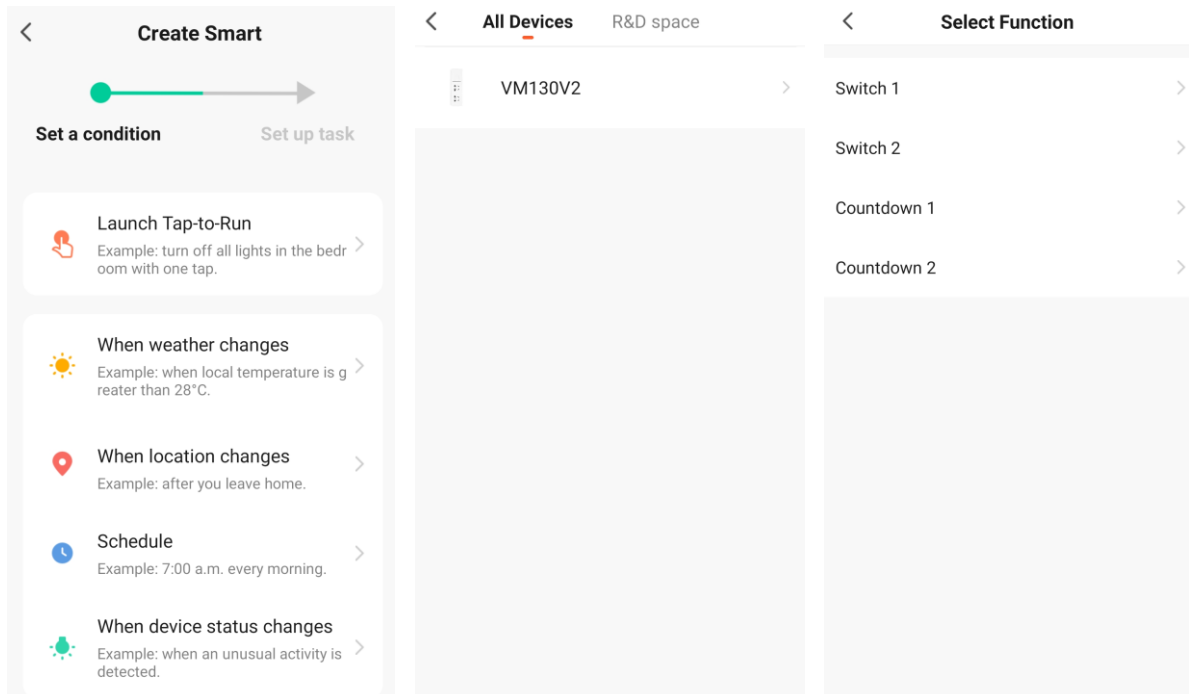

Select the on option (ON). Next, select the "Delay" task and a delay time of 2 seconds.

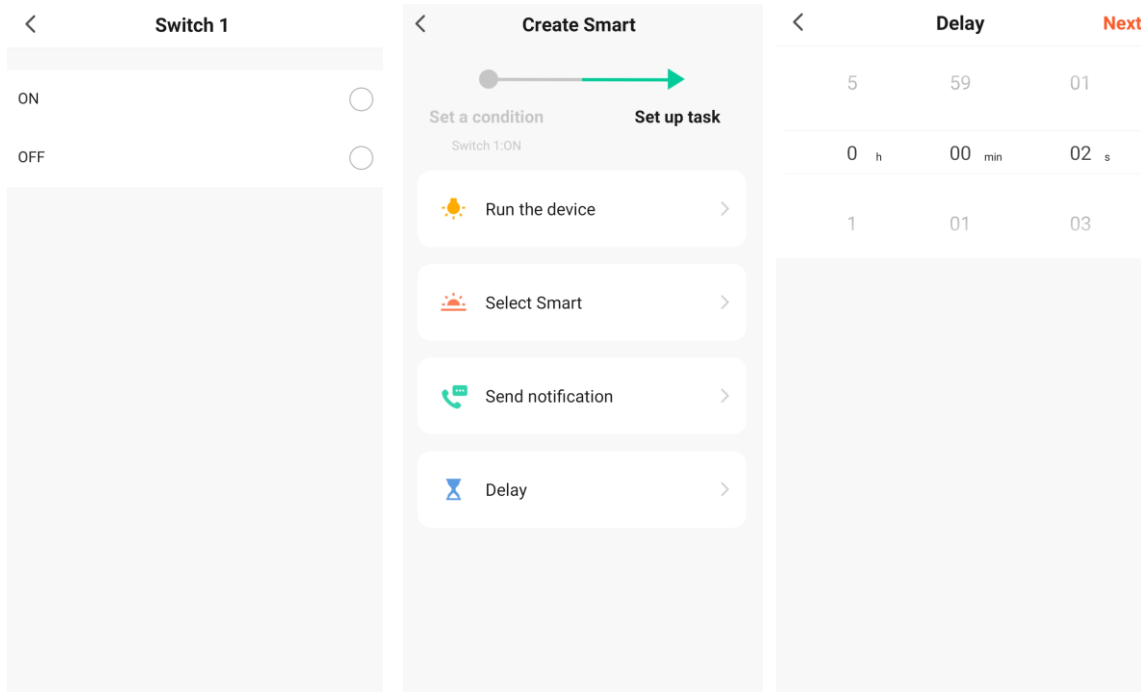

We have an overview of the set 'smart' action. Now, the channel needs to switch off after the set delay. For this, we add another task, where we select "Run the device" and device VM130V2.

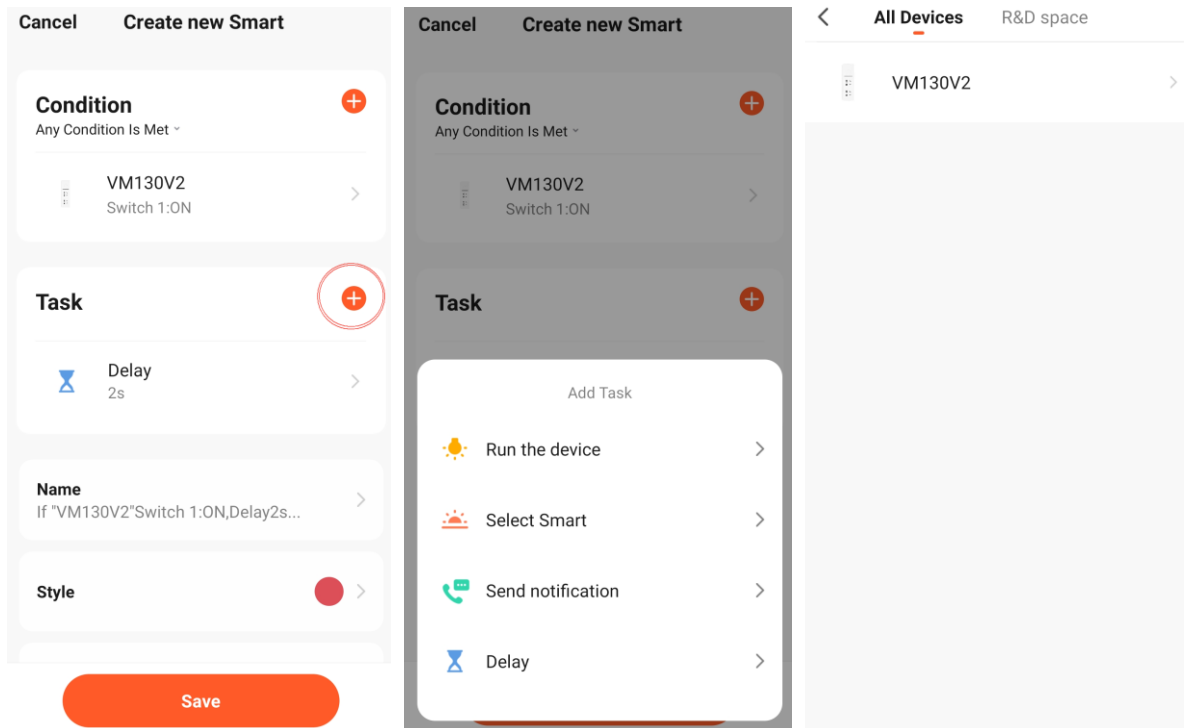

We select channel 1 (Switch 1) and the “OFF” situation. Finally, we have an overview of the set ‘smart’ action: When channel 1 is activated, it will switch off after a delay of 2 seconds.

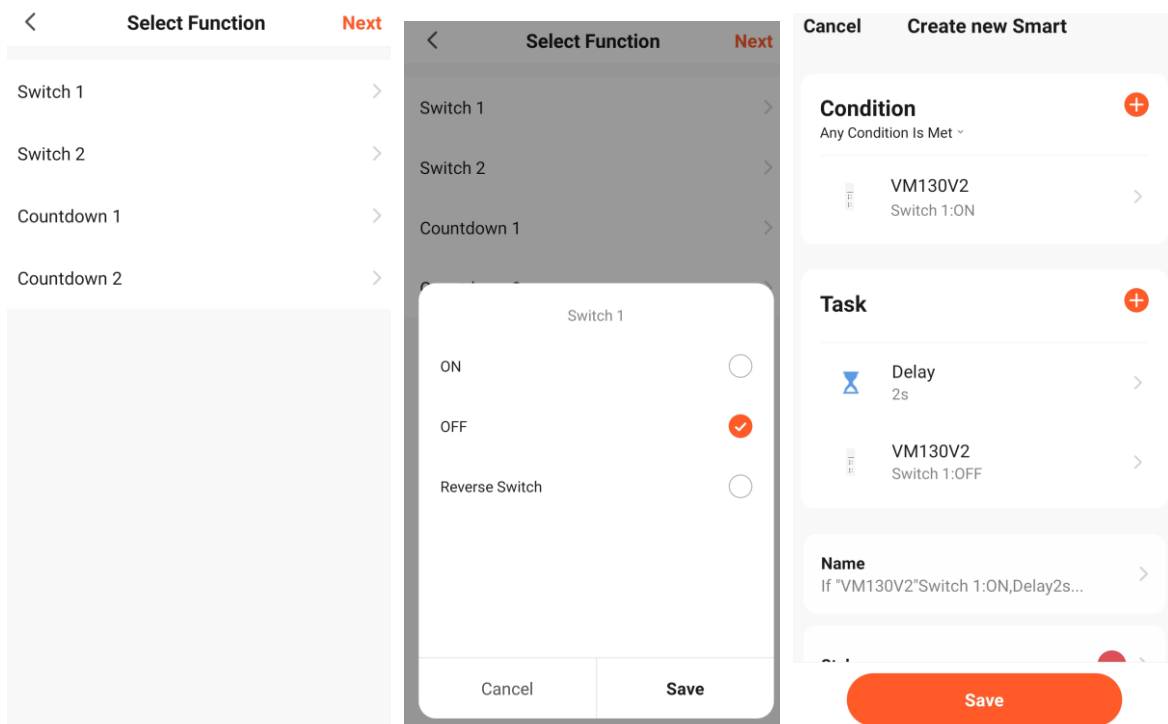

We save the smart action and start using it. The overview window of the smart action shows us that the action has been added and is activated.

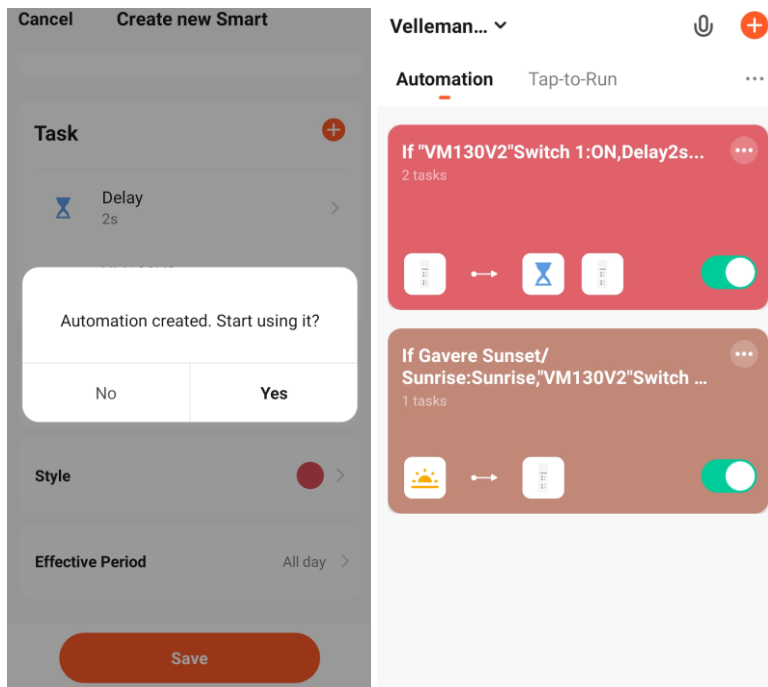

From now on, channel 1 will act as a 'pulse' contact: every time it is activated, it will deactivate after 2 seconds, regardless which input the channel activates (transmitter and TUYA app).

You can add more smart actions to the VM130V2 and couple to other smart devices which you have added to your app. This way, you could couple a VM130V2SET to another VM130V2SET and control one VM130V2 and – via TUYA – the other VM130V2 with only a single transmitter.

Troubleshooting

LEDs and their meaning

LED	Switched on	Switched off	Blinking
Power LED (5)	The module is switched on	The module is switched off	/
TUYA LED (6)	There is a connection with the TUYA IoT cloud	There is no connection with the	Pairing mode activated
CH1 LED (7)	Channel 1 is activated	Channel 1 is deactivated	/
CH2 LED (8)	Channel 2 is activated	Channel 1 is deactivated	/

Poor reception between transmitter and receiver

The VM130V2SET has an operational range of 30 m (open-field range) between transmitter and receiver. Depending on your application, different situations will reduce reception power. Think of concrete walls, metal fences and electromagnetic interference from other electronic devices. Prior to installing the receiver, test different locations until you have the best reception. When reception weakens suddenly, replace the batteries in the transmitter.

Bad reception between the receiver and the TUYA IoT cloud

Frequent reception loss between the VM130V2SET and the TUYA app or SmartLife app is often due to an unstable Wi-Fi connection. Place your smartphone close to the receiver and check the W-Fi strength at that location. Re-install the receiver if necessary or provide a stable Wi-Fi connection.

If problems persist, Velleman offers different DEVOLO Wi-Fi amplifiers for a stable Wi-Fi connection.

8574: DEVOLO MAGIC 1 Wi-Fi Mini Multiroom Kit

8629: DEVOLO MAGIC 2 Wi-Fi Next Multiroom Kit

FAQ

Can I use the VM130V2SET with a previous version?

No, the VM130V2SET is not compatible with previous versions (VM130N, VM130) as the wireless modules use the 433 MHz band.

The TUYA function does not work when I move the receiver.

Check if the receiver has good Wi-Fi reception on its location. If you changed the name of your Wi-Fi network or your password, you will have to re-pair the receiver to the TUYA IoT cloud.

I can hear a click every time the channel switches.

This is perfectly normal. When switching, the channel activates a relay with a mechanical component. The click you hear is the switching of that mechanical part of the relay.

When I switch on the receiver, the relay switch without having used the transmitter.

This is normal. The relays will shortly be activated when switching on the receiver. After a short period, these will be deactivated. That is why we ask you to make sure no devices are connected to the relays at the first set-up and when pairing the transmitter and to TUYA IoT cloud (where you switch the device on and off a couple of times). The VM130V2SET is designed to stay switched on permanently. This situation only happens at start-up.

Does the VM130V2SET work at the 5 GHz Wi-Fi frequency?

No, the VM130V2 only works at the 2.4 GHz Wi-Fi frequency.

Can I modify the RF frequency (433 MHz)?

No, you cannot modify the 433 MHz RF frequency.

Can I buy a transmitter separately to pair to an existing VM130V2SET?

Of course! You can buy the VM130V2-T separately, which is only the transmitter.

RED Declaration of Conformity

Hereby, Velleman Group nv declares that the radio equipment type VM130V2SET is in compliance with Directive 2014/53/EU.

The full text of the EU declaration of conformity is available at the following internet address:
www.velleman.eu. www.velleman.eu.